

La Marzocco Technical Bulletin #47 - NEW PADDLE PARTS

Dear La Marzocco Family Member,

Herewith we would like to inform you about the latest modification on our paddle group assembly.

After machine s/n LINEA 32165, FB3544, GB3558 and GS1106 (produced July 2010), ALL paddle valves are equipped with a new improved internal top spacer (parts on the image below 1-2-3), which increases the whole valve durability and reliability (see picture below).

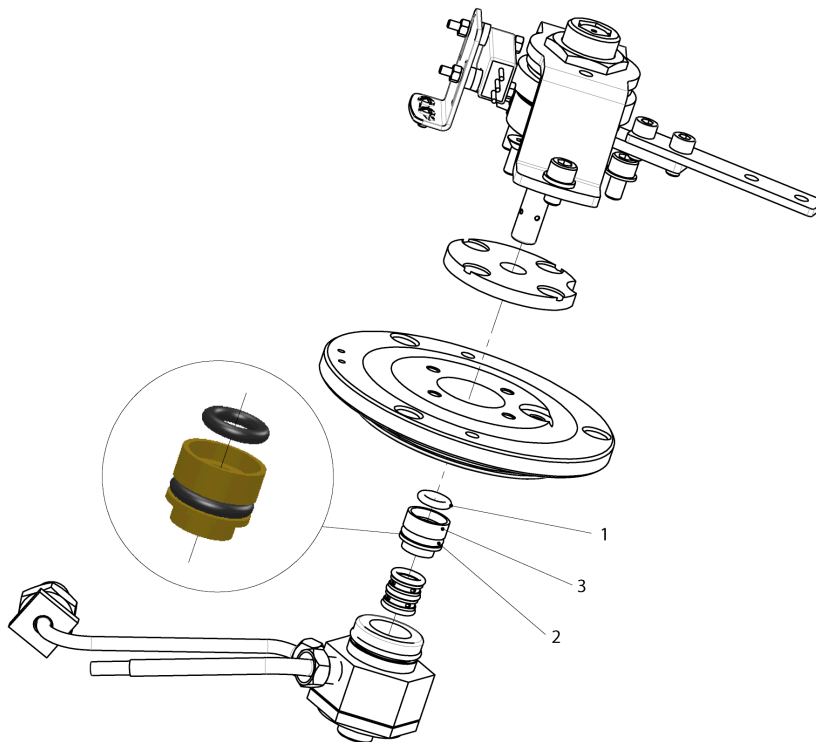

1	H.1.018	OR 109 - (2-110) IN EPDM - 70 SHA
2	H.1.019	OR 113 - (2-111) IN EPDM - 70 SHA
3	B.2.015	INTERNAL SPACER FOR PADDLE

In the table above please find the single codes of the updated parts.

The **WHOLE PADDLE ASSEMBLY** (code # SA600) can be ordered if you still have valves with **FIXED O-RINGS** and **STAINLESS STEEL MAIN SHAFTS** (paddle machines with S/Ns prior to LINEA 30524, GS0785 and GB2481), which have now been replaced by **REMOVABLE BRASS AND RUBBER SPACERS** and a **BLUE Techtron® (***)** shaft.

This new paddle assembly further improves performance and increases lifespan of the valve.

Please do not hesitate to contact me if you need further clarification.

Sincerely yours,

Enrico Wurm

*(***)Techtron® is a revolutionary material with outstanding wear resistance, low coefficient of friction, excellent chemical and hydrolysis resistance, very good dimensional stability and incomparable resistance to elevated temperatures.*