



Marco Beverage Systems Ltd.

INSTRUCTIONS FOR MODEL

Revision 9th Mar 2010

Uber Boiler

P/N: 1000680 Uber Boiler 6L 2.8kW

P/N: 1000681 Uber Boiler 2L 2.8kW

<p>MARCO is an ISO9001:2000 Registered Company.</p>	
---	--

Water pressure : 5 - 50 psi (min.-max.)35 - 345 kPa (min.-max.)

<p>Marco Beverage Systems Limited. 63d Heather Road, Sandyford Industrial Estate, Dublin 18.</p>	<p>Marco Beverage Systems Limited. Shire House, Strixton Manor, Strixton, Wellingborough, Northants, NN29 7PA</p>
<p>Ireland Tel: +353 (0)1 295 2674 Ireland Fax: +353 (0)1 295 3715 email: sales@marco.ie www.marco.ie</p>	<p>UK Tel: +44 (0)2072 744 577 UK Fax: +44 (0)2079 788 141 email: sales@marco-bev.co.uk www.marco-bev.co.uk</p>



UNIT INSTALLATION INFORMATION

SAFETY:

- **Risk of scalding.** Beware of accidentally operating the water drawoff dial or push buttons especially when cleaning. If the dial is left in the ON position (shown later) then pressing boost will cause water to flow immediately from the font.
- This appliance must be earthed. If the plug supplied is not used then ensure that the green/yellow cable is connected to a suitable earth.
- Risk of flooding –inlet hose. The hose supplied with this unit is non-toxic food quality tested to 190psi. However, a hose is not a permanent connection. It is, therefore, advisable to switch off boiler and close the stopcock valve when boiler is not in use, e.g. overnight, weekends etc.
- Risk of flooding –overflow hose. Water spilling in the scale platform area will run down a waste tube which should be plumbed –this is not intended to be used as a dedicated drain facility. If a waste bucket is used it risks overflowing.
- The utmost care has been taken in the manufacture and testing of this unit. Failure to install, maintain and / or operate this boiler according to the manufacturer's instructions may result in conditions that can cause injury or damage to property. If in any doubt about the serviceability of the boiler always contact the manufacturer or your own supplier for advice.
- Children should be supervised to ensure that they do not play with the appliance
- In the event any wires are damaged, such wires can only be replaced by experts or professional afterservice staff from the manufacturer, afterservice department or similar function departments.

INSTALLATION DETAILS:

Electrical installation:

- Electrical specification: 2.8kW-230V-50Hz
- A 13A plug is factory fitted. A suitable 13A outlet is all that is required.

Plumbing installation procedure:

- Mains water pressure required (limits): 5-50psi (35-345kPa)
- Fit a stop Valve on a cold water line and attach a 3/4" BSP male fitting, (e.g. 3/4" x 1/2" 311 or washing machine type stop valve).
- Connect straight tailpiece of the hose to the stop valve fitting. Make sure that the pre-attached sealing washer is fitted.
- Turn on the water to flush any impurities, dust etc from the inlet hose and water pipe. Allow several gallons through.

- Connect right-angled tailpiece of the hose to the inlet valve of the boiler (again 3/4" BSP). Make sure the sealing washer is fitted here also.
- Turn on water and check for leaks.

CLEANING:

The exterior of these machines may be cleaned with a damp cloth and a light detergent. Do not use abrasive cloths or creams, as this will spoil the finish of the machine. Do not use a water jet or spray.

NB: Beware of accidentally operating the Font Dial or buttons when cleaning the front of the machine.

LIMESCALE:

In common with all water boiler manufacturers, service calls resulting from limescale are not covered by warranty. Fitting a scale reducer is recommended, especially in hard water areas. This can reduce the build-up of scale but may not stop it altogether. The frequency that descaling is required depends on the local water supply; hard water areas need more attention. Descaling of the machine should ideally be carried out by qualified service personnel.

Descal agents/solution should be added to the Tank via the large tube as in photo. Follow in the descale agent instructions.



Descal Tube at
front of Unit

Location of On/Off Switch
– under the unit

COUNTER CUTOUT:

- NEVER lift or lower the unit by holding the front!—use the upper wide tile or lift from the base.
- The unit requires a counter thick enough to support the weight of the machine when full, when full it could be up to 30kg in total.
- Never overload the scale platform with a force greater than 9kg.
- Ensure the flow control dial is in the OFF position as shown below.

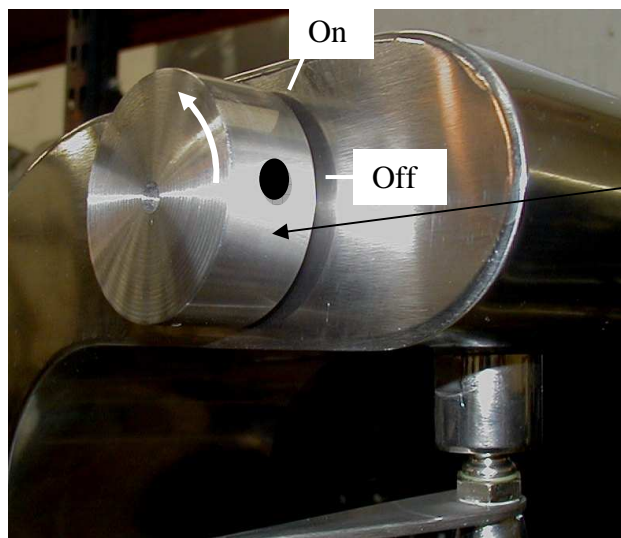

The Font Dial operates anticlockwise to begin the flow of water.

- Check the dimensions shown for the counter cutout and the upper tile, leave adequate clearance on your counter top and check the space below the counter/cabinet to ensure there is enough room.
- Cut out the counter top to be 410x195mm, this dimension includes clearance/tolerance space for the lower part of the machine (the actual machine is approx 405x190mm). The full dimensions are shown on the following page.
- Hold the machine by the tile and slowly lower it down into the cutout, it is advisable to wear thick work gloves. A second person may be needed who could hold the machine at the bottom. Be careful not to trap fingers under the tile as it is lowered.
- The weight of the machine when filled should be enough to ensure it is not moving. If further fixing is required it silicone can be used to stick the tile to the counter—but it is advisable to leave the machine free to be taken out for servicing purposes.

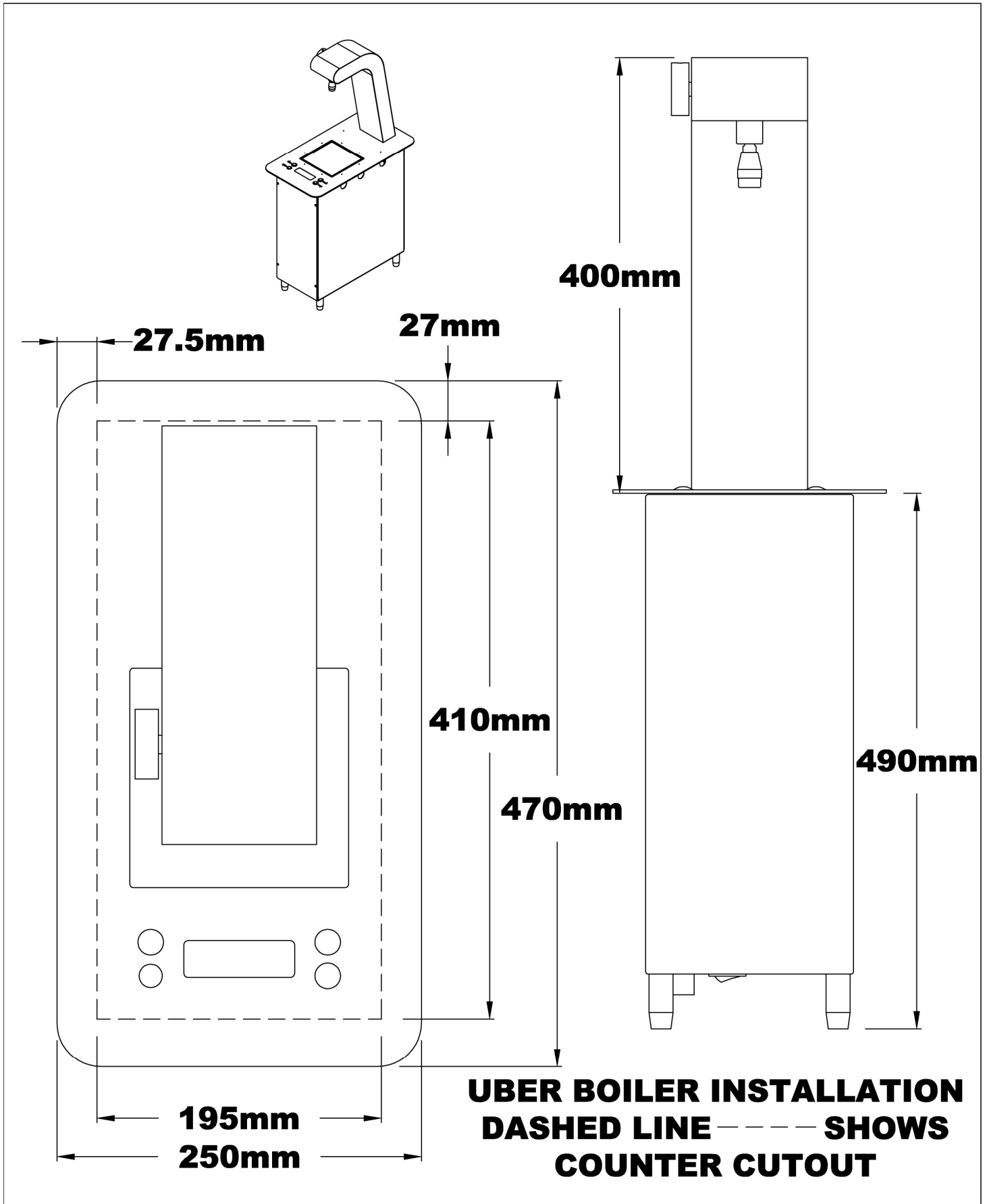



Principle of Operation of the Uber Boiler

- The Uber Boiler is designed to be a highly accurate hot water delivery system. This temperature accuracy is achieved by several features;
 - In stand-by the water is maintained at a set temperature [Prime Mode] this is controlled via a thermistor in the tank,
 - in the Boost Mode the hot water is circulated through the FONT (to reduce any temperature loss)
 - a second thermistor located in the FONT is now used to control the temperature of the water and therefore ensure the accuracy of the delivered water
 - a specialised software algorithm is used to control the temperature within +/- 0.2°C,

Simplified operation :

1. The unit is preset to a Prime Temperature at the factory (this may be changed by the user). This is the stand-by mode and the temperature is displayed on the display panel as Tank Temp.
2. The user presses the Boost button and holds this button down until the desired set temperature is displayed on the display panel.
3. The Uber Boiler will now ramp the tank temperature from the Prime setting up to the Set Temp while recirculating the water through the Font.
4. When the set temperature is reached the user will rotate the Font Dial counterclockwise to start the flow of water.
5. To select another set temperature the user should press the Prime button – return the unit to the Prime Mode – and repeat step 2 to the new temperature.

FIRST OPERATION :

- Check that all installation procedures have been carried out.
- Ensure water valve is on.
- Plug boiler into 13A socket and press power switch on – located under the bottom of the Tank unit.
- See Photo 1 for location and name of each feature.
- The boiler unit will then take in water to the high level probe and then commence heating – this is known as a continuous fill cycle
- The display will show : PRIME FILL the TEMP : will show the temperature of the water in the tank.

- Once the water level in the tank has reached the high level probe (full) the heater will operate and it will take approximately 20-25 minutes to reach the PRIME temperature. On the display : PRIME HEAT
- Once the PRIME temperature has been reached the display will indicate : PRIME READY
- The boiler is now ready for use
- Use of the Time and Weigh Features:
 - Time : 00:00 – when the Timer Button is pressed the display will indicate time elapsed in minutes : seconds. This can be used to indicate the brewing time. Pressing the button once quickly will pause the current time which can be restarted again. Pressing the button for more than 2 seconds resets the Timer display to zero.
 - Weight : 0000 – this is in grams. Pressing the Weigh button will reset the weighing scale. The brewing vessel can be placed on the scale/drip tray and the display will show its weight. Pressing the Weight button again will “zero” (tare) the scale so that when the coffee grind is added to the basket, its weight can be displayed. This is to help control the Coffee / Water ratio. 1ml of water weights approx 1gram.
 - 9kg is the max allowable weight on the scales. **DO NOT OVERLOAD**

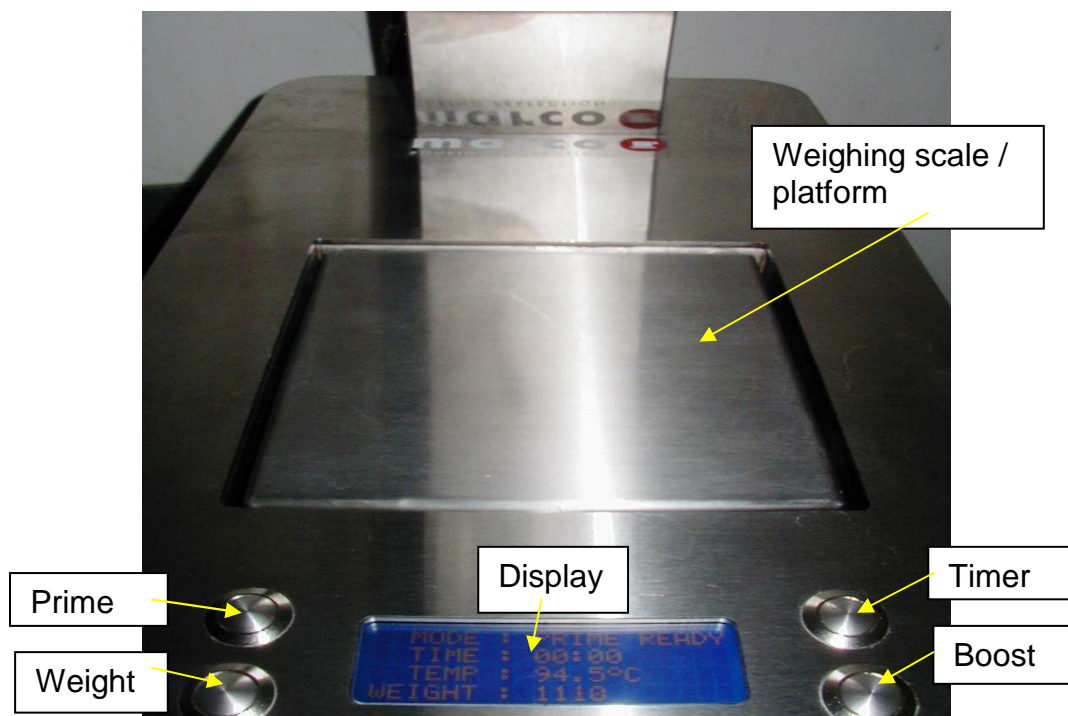

Photo 1



UNDERSTANDING THE DISPLAY AND CONTROLS:

The Display screen contains 4 Lines of information



1. First line on the display shows *status message*:

Status	Description
PRIME FILL	Tank is filling, not heating until reaches the top level probe. Boost button disabled.
PRIME HEAT	Tank is heating, not filling until temperature in the tank reaches "Prime temp". Boost button disabled.
PRIME READY	Tank is heated up to the "Prime temp". Occasionally it will refill (if water evaporates) and reheat once the temperature falls 0.5°C below "Prime temp". Boost button is operational and puts machine into BOOST mode.
BOOST	MANUAL BOOST mode. Water inlet disabled. Heater off. (BOOST button released). Press PRIME button to go back to PRIME mode.
BOOSTING	MANUAL BOOST mode. Water inlet disabled. Heater on. (BOOST button pressed). If any of the temperatures (font or tank probe) will go above "Max temp" the heater will go off and screen will show BOOST even if the BOOST button is pressed. Press PRIME button to go back to PRIME mode.
SET TEMP: xx.x °C	AUTO BOOST mode. Water inlet disabled. Shows the target temperature set by pressing and holding BOOST button. Machine heats up to the set temperature and maintains it within ±0.2 °C. Press PRIME button to go back to PRIME mode.
Communication error!	Display board lost communication with boiler PCB (can not receive serial data about temperature and probes). All actions cancelled. Whenever communication is restored, machine will go back to PRIME FILL mode.
Low level probe err!	Top water level probe covered while low level not. Check low level probe for scale. Boost button disabled.
Tank thermistor err!	Tank thermistor disconnected or short circuited. Boost button disabled.
Font thermistor err!	Font thermistor disconnected or short circuited. Boost button disabled.

2. The second line shows the live readout of:

- Tank temperature in PRIME mode,
- Font temperature in BOOST mode.

3. Third line shows the timer

- Clicking TIMER button turns on and off timer clock.
- Pressing it for longer than 2 seconds resets it and turns it off.

4. Fourth line shows measured weight, scaled in grams.

- Numbers above 9999 can NOT be displayed – “----“ will be shown instead.
- Negative numbers will be shown with minus sign (down to -9999).
- Pressing WEIGHT button will reset scale to zero.
- Please note that the max weight for the load cell is 4kg and any loads higher than 9kg may destroy it.
-

NOTE: Because the boiler is electronically controlled no priming is necessary.
The element cannot switch on until a safe level of water is reached.

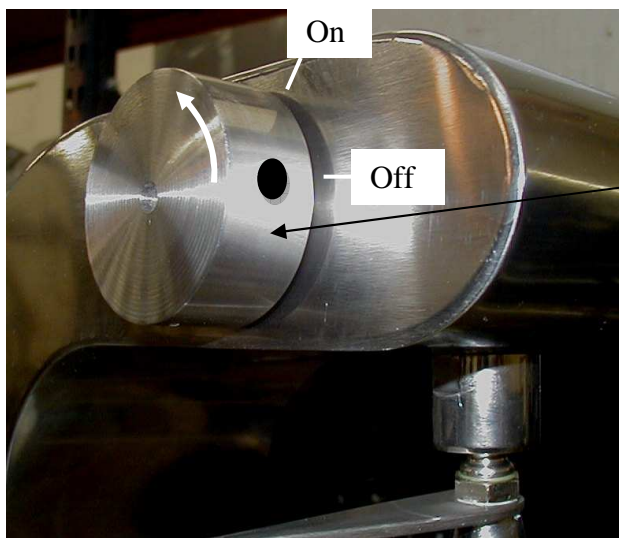

The Font Dial operates anticlockwise to begin the flow of water.

WARNING: ALWAYS ENSURE THE DIAL IS SET TO OFF BEFORE PRESSING BOOST OR HOT WATER WILL BE FLOWING IMMEDIATELY.



MODES OF OPERATION

The uber Boiler has 2 modes of operation:

- 1 PRIME Mode
- 2 BOOST Mode, this may be operated in
 - Manual Boost or
 - Auto Boost mode.

PRIME MODE

After turning on or pressing PRIME button the machine goes into Prime Mode.

This is a stand-by mode when the water is prepared for final dispense.

The tank will fill to the top level probe (PRIME FILL) and heat up (PRIME HEAT) to the preset temperature (*Prime temp* in calibration). Once the temperature gets above (*Prime temp* - 1°C) the display will show PRIME READY message and the BOOST button will be enabled.

Occasionally when the water evaporates the machine will refill and show PRIME FILL message for few seconds before going back to PRIME READY again.

Prime Mode logic is based on thermostatic principal – the water accuracy is around ±2°C from the set point.

Prime Mode status	Description	BOOST button	Pump
PRIME FILL	Tank fills to the top probe; heater off.	disabled	OFF
PRIME HEAT	Tank heats up to the preset <i>Prime temp</i>	disabled	OFF
PRIME READY	Tank temperature above (<i>Prime temp</i> - 1°C). Once the temperature falls below (<i>Prime temp</i> – 3°C) the machine will go back to PRIME HEAT	enabled	OFF

BOOST MODE

The UBER Boiler with 1.5 Rev Programme may be operated in one of two Boost Modes.

In the **Manual Boost** mode the user controls the heating process by holding the Boost button until the desired temperature is achieved.

In the **Auto Boost Mode** the user sets the desired temperature and releases the Boost Button – the controller will manage the heating cycle to achieve the desired temperature.



Manual Boost Mode

In Manual Boost Mode the heater is controlled manually by BOOST button. If the temperature read by any of the sensors (tank or font) is higher than the *Max temp* the heater will go off even if the BOOST button is pressed.

This mode is turned on by setting *Delta* value to 0.0 in *Calibration Mode*.

Boost Mode status	Heater	Pump
BOOST	Heater off	ON
BOOSTING	Heater on	ON

Auto Boost Mode

In Auto Boost Mode user sets the desired temperature. It is done by pressing (and holding) the BOOST button to increase SET TEMP (shown on the screen) in 0.1°C steps. The set-up temperature range is between *Prime temp* and *Max temp*.

After setting-up the machine will start to heat to the desired temperature and will maintain it within $\pm 0.2^{\circ}\text{C}$. The SET TEMP may be increased at any time by pressing the BOOST button. Pressing PRIME button will make the machine go back to Prime Mode and reset the SET TEMP back to *Prime temp*.

The Auto Boost Mode is based on Advanced Proportional Logic (APL) control algorithm that will perform heating in few steps measuring errors each time to keep the temperature overshoots small.

Über Calibration (software ver 1.5)

The following information is for Calibration purposes and should not be required for normal use conditions.



To enter calibration mode press all four buttons on the front tile at the same time. Buttons on the left hand side change calibration option (up/down): See options below

1. Tank Temp Offset
2. Font Temp Offset
3. Prime Temp
4. Max Temp
5. Delta value
6. Dead Time
7. Boost Timeout
8. Scale zero & 1kg
9. Save & exit

Buttons on right hand side adjust the calibrated value (up/down, press longer to repeat).

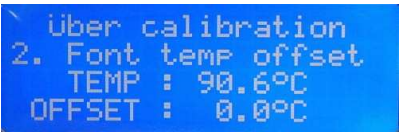
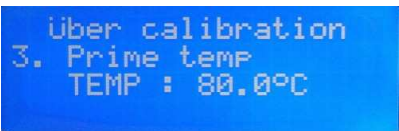

Calibration Options their Description and Default values.

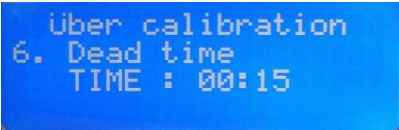
Screen view Options 1 - 9	Description	Default value
	<p>Sets offset value for tank temperature sensor. The offset is the difference between absolute temperature and a measured one. It is factory set using calibrated instruments. TEMP shows live readout from tank sensor with the applied offset.</p>	<p>0.0</p>
	<p>Sets offset value for font temperature sensor. The offset is the difference between absolute temperature and a measured one. It is factory set using calibrated instruments. TEMP shows live readout from font sensor with the applied offset.</p>	<p>0.0</p>
	<p>Sets temperature at which the element clicks off in prime mode. The turning-on temperature is 0.5 degree below this point.</p>	<p>(89.0 for 2L) (90.0 for 6L)</p>
	<p>Sets maximum temperature at which the element can be switched on. Both sensors (tank and font) are monitored, if any reading is above set value, the element goes off.</p>	<p>97.5</p>
	<p>Sets heating delta factor. This number tells the software how many energized seconds it will take to heat up the tank by one degree. This number is proportional to the size of the tank and inversely proportional to the power of the element. Setting value too high will make the machine overshoot too much; setting too low will make the process of reaching the set temperature slower. Setting value to 0 enables MANUAL mode (see <i>MANUAL BOOST MODE</i> section).</p>	<p>(8.0 for 2L) (13.0 for 6L)</p>
	<p>Sets dead time (measured in seconds from the beginning of every heating cycle in BOOST mode) when software waits for the tank sensor to record temperature change. Value depends on element time constant and placement of the thermistor. Setting the value too high will make temperature swing too much in BOOST mode; setting too low will make machine overshoot too much. Not valid in MANUAL mode (can have any value).</p>	<p>00:12 (for both 2L & 6L,)</p>



<pre>Uber calibration 7. Boost timeout TIME : 06:00</pre>	<p>Sets BOOST mode time-out. Timer starts at the beginning of the BOOST mode. Machine goes back to PRIME mode after that time to avoid unit being left in Boost Mode for too long.</p>	<p>06:00</p>
<pre>Uber calibration 8. Scale zero & 1kg WEIGHT : 1000 g TIME=zero BOOST=1kg</pre>	<p>Calibrates weighing scale. 1kg weight is needed. Do NOT press any of the right hand side buttons if you don't have any reference weight! TIMER button sets scale to zero; BOOST button sets new value for 1kg. To recalibrate the scale:</p> <ul style="list-style-type: none"> - empty the weighing platform, - press TIMER button (reset scale to 0), - place 1kg calibration weight, - press BOOST button (set new value for 1kg) <p>WEIGHT shows live readout of the weight.</p>	<p>-</p>
<pre>Uber calibration 9. Save & exit Press TIME to accept</pre>	<p>Press TIME button to accept all the settings – they will be stored in the non-volatile memory. To cancel and come back to the previous settings – turn the machine off and on again.</p>	<p>-</p>