

manual

strada x

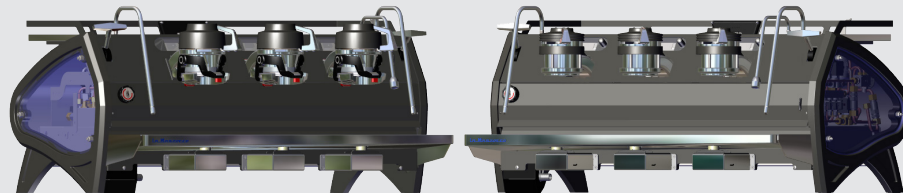

la marzocco

handmade in florence

strada x

Operating Manual V2.1 - 12/2024



Chapters

- | | |
|--|---------|
| 1. General Warnings and Safety Specifications | page 3 |
| 2. Definition of Available Models | page 8 |
| 3. Installation | page 11 |
| 4. Machine Operation and Coffee Preparation | page 20 |
| 5. Dispensing Steam and Hot Water | page 23 |
| 6. Maintenance and Periodic Cleaning Operations | page 24 |
| 7. De-commissioning and Demolition | page 27 |
| 8. Mandatory Maintenance and Check-up Operations | page 28 |
| 9. Precision Scale | page 29 |
| 10. Straight-in (if present) | page 32 |
| 11. Software Programming Guide | page 34 |

certifications available:



la marzocco

handmade in florence

La Marzocco S.r.l.

Via La Torre 14/H
Località La Torre
50038 Scarperia e San Piero
(Firenze) - ITALIA

www.lamarzocco.com
info@lamarzocco.com

T: +39 055 849 191
F: +39 055 849 1990

Original instructions verified by the manufacturer.



Scan QR Code to view the complete Software Programming Guide available on the techcenter website.

Printed on recycled paper.

1. General Warnings and Safety Specifications

WARNING

This machine is for professional use only and should be installed in locations where its use and maintenance is restricted to trained personnel. Children are forbidden to operate or play with the machine.

WARNING

The Coffee machine must be placed in a horizontal position on a counter higher than 80 cm from the ground.

WARNING

This machine is not suitable for outdoor use. Jets of water should not be used to clean the machine, nor should it be placed where water jets are used.

CAUTION

As already mentioned in the preceding notes, the manufacturer shall not be held responsible for damage to objects, animals and/or people whenever the machine has not been installed according to the instructions contained in this manual, and is not used to do what it was designed for (i.e. preparing coffee and hot drinks).

1) Important safeguards

- The weighted sound pressure level of the machine is lower than 70dBA.
- Use, cleaning and maintenance of this coffee machine are realized by

people (including children more than 8 years of age) with reduced physical, sensory or mental capabilities, or lack of experience and knowledge, as long as they have been given supervision or instructions concerning the use of the appliance by a person responsible for their safety and if they understand dangers.

- Children should be supervised to ensure that they do not play with the appliance.
- Keep the appliance and its cord out of the reach of children less than 8 years of age.

2) This operating manual is an integral and essential part of the product and must be supplied to users. Users are asked to read the enclosed warnings and cautions carefully, as they provide valuable information concerning safety during installation, operation and maintenance. This manual must be kept in a safe place and be available for consultation to new and experienced users alike.

3) Ensure product's integrity by inspecting the packaging, making sure it presents no signs of damage which might have affected the enclosed machine.

4) Check the machine's integrity after having carefully removed the packaging.

Note: In case of doubt, do not go on any further and contact your dealer or retailer immediately. They will send out specialized personnel authorized to perform service on the espresso machine.

5) Packaging (boxes, plastic bags, foam parts and whatever else) must not be left around within easy reach of children, due to the potential danger it represents, nor be discarded in the environment.

6) Check to see that data on the rating plate corresponds to those of the main electrical supply which the machine will be hooked up to.

7) The equipment must be installed to comply with the applicable federal, state or local electrical and plumbing codes. The installation also must comply to the

manufacturer's instructions, and must be performed by qualified and authorized personnel.

8) Incorrect installation may cause for injury/damages to people, animals or objects, for which the manufacturer shall not be held responsible.

9) Safe electrical operation of this device will be achieved only when the connection to the power outlet has been completed correctly and in observance of all local, national, and international electrical codes and safety regulations, and particularly by grounding the unit. Make sure grounding has been done properly as it represents a fundamental safety requirement. Ensure qualified personnel check

such connection.

10) Furthermore, you must ensure that the capacity of the available electrical system is suitable for the maximum power consumption indicated on the espresso machine.

11) We do not recommend using adapters, multiple plugs and/or extension cords. If you cannot avoid using them, make sure that they are exclusively of the kind which conforms to local, national, and international electrical codes and safety regulations, being careful not to exceed the power and current ratings indicated on such adapters and extension cords.

12) This device must be used exclusively for the functions it has been designed and built for. Any other application is

inappropriate and dangerous.

The manufacturer shall not be held responsible for any damages caused by improper and/or irrational use.

This machine should not be installed in kitchens.

13) Using any electrical device requires that certain fundamental rules be observed. In particular:

- do not touch the device with wet or humid hands and feet;
- do not use the device while having no shoes on your feet;
- do not use extension cords in bath or shower rooms;
- do not unplug the device from the power outlet by pulling on the power supply cable;
- do not expose the device to

atmospheric agents (rain, sun, etc.);

- do not allow children or untrained people to use this device;
- do not clean the control panel with a wet cloth since it is not watertight.

14) Before carrying out any maintenance and/or cleaning operations, turn the main switch, which is located on the front left of the machine, to the “0” or “OFF” position, and disconnect the machine from the electrical network by unplugging the cord or by switching off the relative circuit breaker. For any cleaning operation, follow exclusively the instructions contained in this manual.

15) In case the machine is operating in a faulty manner

or breaks down, disconnect it from the electrical network (as described in the preceding point) and close the water supply valve. Do not attempt to repair it. Contact a qualified and authorized professional to perform any repair. Any repairs must be performed exclusively by the manufacturer or by an authorized centre using only original parts. Non compliance with the above could compromise the safe operation of the machine.

16) You should plan to make use of an omnipolar connector during installation, as required by local, national, and international electrical codes and regulations.

17) In order to avoid dangerous overheating problems, it

is recommended that the power supply cable be fully unfurled.

18) Do not obstruct air intake and exhaust grilles and, in particular, do not cover the cup warmer tray with cloths or other items.

19) The machine's power supply cable must not be replaced by users. In case the power supply cable becomes damaged, shut off the machine and disconnect the machine from the electrical network by switching off the relative circuit breaker and close off the water supply; to replace the power supply cord, contact qualified professionals exclusively.

20) These instructions are also available in an alternative format on a website

<http://techcenter.lamarzocco.com>.

21) The machine should be placed on a flat counter and must be placed in settings with the following temperatures:

Minimum room temperature: 5°C/41°F;

Maximum room temperature: 32°C/89°F.

22) Check the package to make sure that the following accessories are included:

- a number of 1-dose and 2-dose portafilters corresponding to the number of groups;
- replacement 1-dose and 2-dose filters (one of each);
- 1 tamper;
- 1 blind filter;
- cleaning detergent, for the groups;

- 3 stainless steel braided hoses for water connections;
- 1,5 mt of reinforced plastic tubing for drainage;
- 1 hose clamp;
- 1 TEE Fitting.

23) If the machine has been temporarily housed in settings with a room temperature of less 0°C/32°F, the machine must be placed in a warmer environment in order to gradually defrost the hydraulic system prior to use.

24) Water pressure supply must be between 0,2 and 0,6 MPa.

The maximum inlet water pressure shall be at least 1,0 MPa (Denmark, Norway, Sweden, Finland).

25) The machine is intended to be permanently connected to fixed wiring, and it is

mandatory that a residual current device (RCD) with a rated residual operating current not exceeding 30mA is installed.

26) This machine is designed only for preparing coffee and hot drinks.

27) Any modification to the equipment is prohibited; the manufacturer cannot be held liable for damage to property, animals, and/or persons if the equipment undergoes technical and aesthetic changes, changes in performance and characteristics, and in general is tampered with in one or more of its constituent components.

28) Minimum requirements for WiFi connection:

- device running Android version 6+ or iOS version 10+;
- wireless network 2.4 GHz;

- La Marzocco app available at the official stores Play Store and App Store.



29) Common Dimensions, Weights, and Features

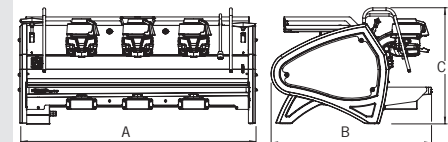

STRADA X	2 groups	3 groups
A [mm]	830	1030
B [mm]	690	690
C [mm]	500	500
WEIGHT [kg]	94	101

2. Definition of Available Models

This operating manual refers exclusively to the following models, of our own manufacture:

STRADA 3 group Electronic Paddle: 3X

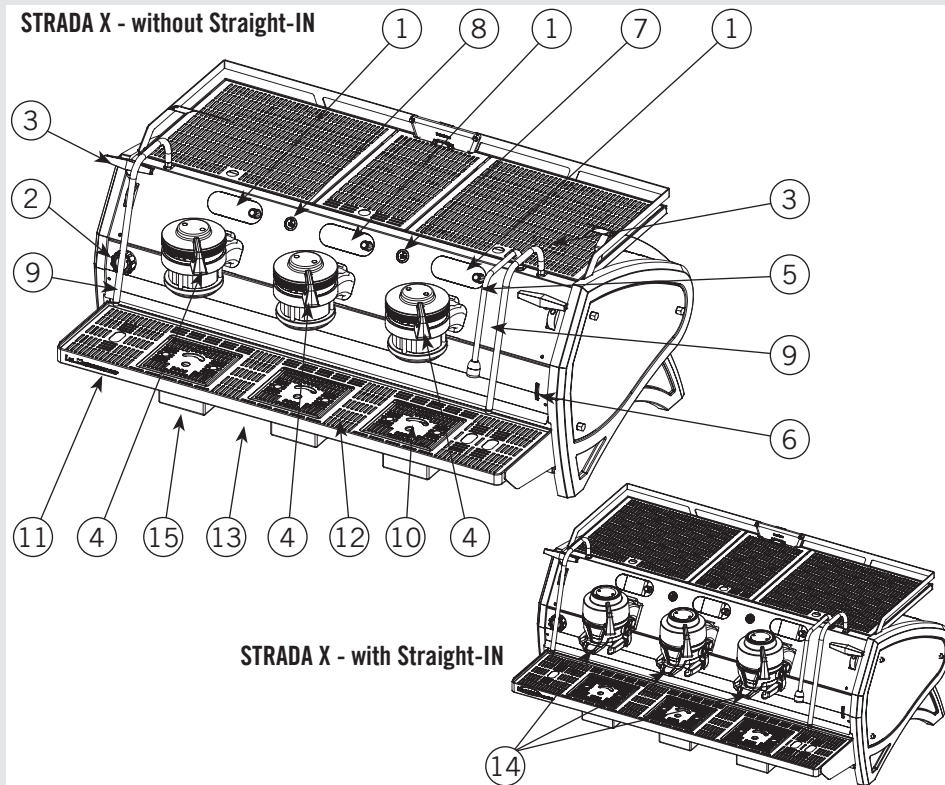

Legend

- 1 Group Display
- 2 Main Switch
- 3 Steam Wand Lever
- 4 Electronic Brew Paddle Lever
- 5 Hot Water Wand
- 6 Hot Water Mix Valve
- 7 Water Button
- 8 Cup Warmer Button
- 9 Steam Wand
- 10 Removable Drain Tray
- 11 Waste Water Hose Holder
- 12 Drain Tray Grate
- 13 USB Key Connection
- 14 Straight-in (if present)
- 15 Precision Scale

For additional information on electronics, keypads, and software programming, please see the section entitled Software Programming your Espresso Machine.

Fig. 1 - Model X with 2 or 3 groups

1) General description

The machine is built in 2 or 3 coffee group versions and is essentially composed of the following parts:

- Steam Boiler (produces steam and hot water);
- 2 or 3 coffee boiler (“saturation”)
- Brewing groups;
- Exterior Cover;
- Water pump.

2) Description of the various parts

• Steam boiler

The Steam Boiler consists of a cylindrical tank, of varying length according to the number of coffee groups, which is made of AISI 300 series stainless steel. Each unit is subjected to a hydraulic test, at a pressure of 6 bar, and has an operating pressure of 1.3-1.5 bar. The following is a list of effective volumes and power ratings according to the number of groups installed:

2 groups	8,2 liters	3000 Watts
3 groups	11,8 liters	4000 Watts

Covers are welded at either end of the cylindrical tank and on one of them there is a housing for the water heating element, which allows the steam boiler to reach operating pressure within approximately 25 minutes. Operating pressure is maintained by temperature probe and PID controller. The steam boiler has various fittings used

for safety devices, for supplying hot water and steam, and for the heating element.

Composed of AISI 300 series stainless steel tube. Heating is accomplished through an immersion-type plated heating element.

- Operating pressure of 1.3-1.5 bar, controlled automatically through a pressure switch or a temperature probe, adjusted to open the heating element supply circuit at 1.5 bar and close it at 1.3 bar.
- The pressure is displayed by means of a pressure gauge with a scale of 0 to 2 bar.
- Safety device, based on an expansion type mechanical valve, with counteracting spring adjusted to 1.8 bar.
- Testing: hydraulic test at 4.5 bar performed on ready-to-use small boilers, at our factory.

• Coffee boiler

The Coffee Boiler consists of a cylindrical tank which is made of AISI 300 series stainless steel. One each group (hot water generator for brewing coffee).

Each unit is subjected to a hydraulic test, at a pressure of 18 bar, and has an operating pressure of 9 bar. The following table is a list of effective volumes and power ratings according to the number of groups installed:

2 groups	2 x 1,3 liters	2 x 800 Watts
3 groups	3 x 1,3 liters	3 x 800 Watts

Covers are welded at either end of the cylindrical tank and on one of them there is a housing for the water heating elements. The temperature of the coffee boiler is maintained by an electronic temperature controller (PID capable) with an accuracy of 0.2°C. The brewing groups are installed on the boiler.

Composed of an AISI 300 series stainless steel tube. Heating is accomplished through an immersion-type plated heating element.

- Operating temperature 95°C (adjustable), controlled automatically by an electronic temperature controller with an accuracy of 0.2°C. Operating pressure of 9 bar, developed mechanically by a special positive-displacement pump which is activated automatically every time coffee is brewed.
- Pressure is displayed through a pressure gauge with a scale from 0 to 15 bar.
- Safety device, based on an expansion type mechanical valve, with counteracting spring adjusted to 13 bar.
- Testing: Hydraulic test at 18 bar performed on ready-to-use small boilers, at our factory.

• Brewing groups

They consist of a precision casting made of stainless steel. The brewing group accepts the portafilter used to hold the ground coffee; the espresso flows through the brewing group, through the portafilter

3. Installation

MODEL/SERIES	GROUP	V/Hz	RATED POWER (W)	RATED INPUT (A)	COFFEE BOILER WATTAGE	STEAM BOILER WATTAGE	TOTAL WATTAGE	POWER CORD SIZE (mm ²)
STRADA X	2GR	AC220-240V/60Hz AC208-240/60Hz AC380/50Hz	5666	25 18 10,3	1600	3000	5666	SEE ELECTRICAL CONNECTIONS FOR DETAILS
	3GR	AC220-240V/60Hz AC208-240/60Hz AC380/50Hz	7783	33,8 30,9 14,8	2400	4000	7783	

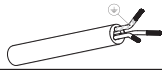
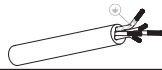
<p>3 X WIRES 220V</p> <p>1 X BLUE (NEUTRAL) 1 X BROWN (PHASE) 1 X YELLOW & GREEN (GROUND)</p> 	<p>POWER CORD:</p> <p>5 X WIRES 380V</p> <p>1 X BROWN (PHASE) 1 X BLUE (NEUTRAL) 1 X GRAY (PHASE) 1 X YELLOW & GREEN (GROUND) 1 X BLACK (PHASE)</p> 	<p>WARNING</p> <p>THE DETAILS ON THE LEFT DESCRIBE HOW TO CONNECT EACH WIRE TO THE PLUG. RESPECT ALSO THE LOCAL SAFETY REGULATIONS.</p>
--	---	--

(ONLY FOR ETL) POWER CORD:

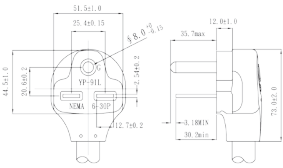
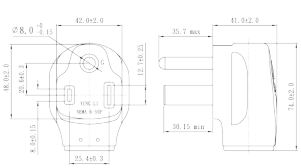
<p>ONLY FOR 2 GROUPS: NEMA 6-30P</p> 	<p>ONLY FOR 3 GROUPS: NEMA 6-50P</p> 
---	---

WARNING

The machine is intended to be permanently connected to fixed wiring, and it is mandatory that a residual current device (RCD) with a rated residual operating current not exceeding 30mA is installed.

WARNING

The Coffee Boiler and Steam Boiler contain water at elevated temperature. Water temperature over 125°F / 52°C can cause severe burns instantly or death from scalding (Coffee Boiler 207°F/97°C - Steam Boiler 256°F / 124°C)

WARNING

Replace fuses with the same size, type and rating. e.g. F1 = 2A, 250V

WARNING

At each installation, the machine should be equipped with a new set of tubes for plumbing and related gaskets.

WARNING

Water pressure supply must be between 0,2 and 0,6 MPa if sufficient pressure is not available we suggest that an additional water supply system is used.

WARNING

Before making any electrical connections make sure that the two strain relief connectors are firmly secured to the body of the machine in order to prevent inadvertent stress on the power cables.

WARNING

This machine should not be installed in kitchens.

WARNING

Hazardous voltage disconnect from power supply before servicing.

WARNING

The motor pump must be situated close to the machine in an accessible place for maintenance but not for accidental interference and where there is an optimal air circulation.

WARNING

The manufacturer declines any responsibility for any event leading to liability suits whenever grounding has not been completed according to current local, national, and international regulations and electrical codes, or other electrical parts have been connected improperly.

WARNING

This appliance is not intended for use by persons (including children) with reduced physical, sensory or mental capabilities, or with lack of experience and knowledge, unless they have been given supervision or instruction concerning the use of the appliance by a person responsible for their safety.

WARNING

- U.S.A. and CANADA only - Do not connect to a circuit operating at more than 150V to ground on each leg.

WARNING

This machine is not suitable for outdoor use. Jets of water should not be used to clean the machine, nor should it be placed where water jets are used.

WARNING

In order to prevent cracks or leakage: do not store or install the Coffee machine in places where in boiler or hydraulicsystem to freeze.

WARNING

Disconnect from power supply before the connection with the water pump.

Note:

- The drinking water mains valve and the circuit breakers for the electrical system need to be located in the most convenient position for the operator to access them easily and quickly.
- This machine complies with the standard 61000-3-11, the impedance at the supply interface must be $Z_{max} = 0.041 \Omega$.

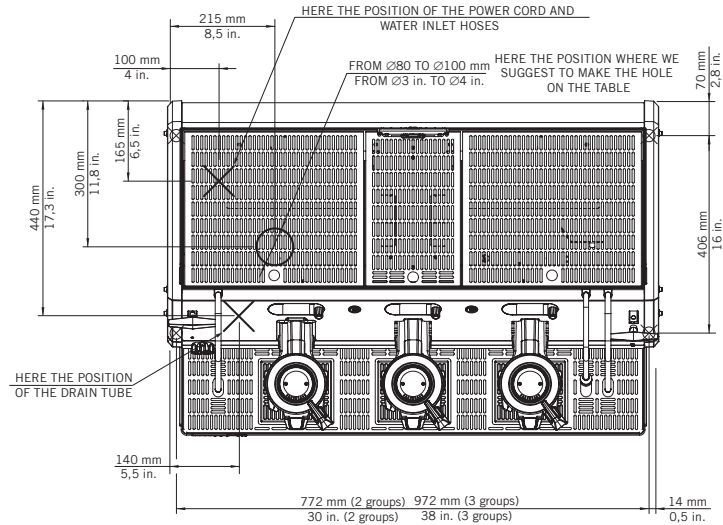

Fig. 2 - Installation on the counter

1) Installation guide

For best results, STRADA needs a minimum flow of water in input of 100 l/h and a pressure of 2.5 bar.

Installations that do not meet these requirements will cause a shorter life of the pump and may cause a high noise level during coffee brewing.

If the pressure and flow are not adequate, air bubbles may develop within the gears. This is called cavitation. Cavitation can impair the performance of the espresso machine.

If the incoming water of the espresso machine falls outside the recommended parameters, it is necessary to carry out one of the following installations:

Pressure lower than 3 bar Flow rate lower than 100 l/h

Installation with the rotary pump (set to 3 bar) immediately after the water treatment system, upstream of the tee.

Enter the programming menu and enable the second pump.

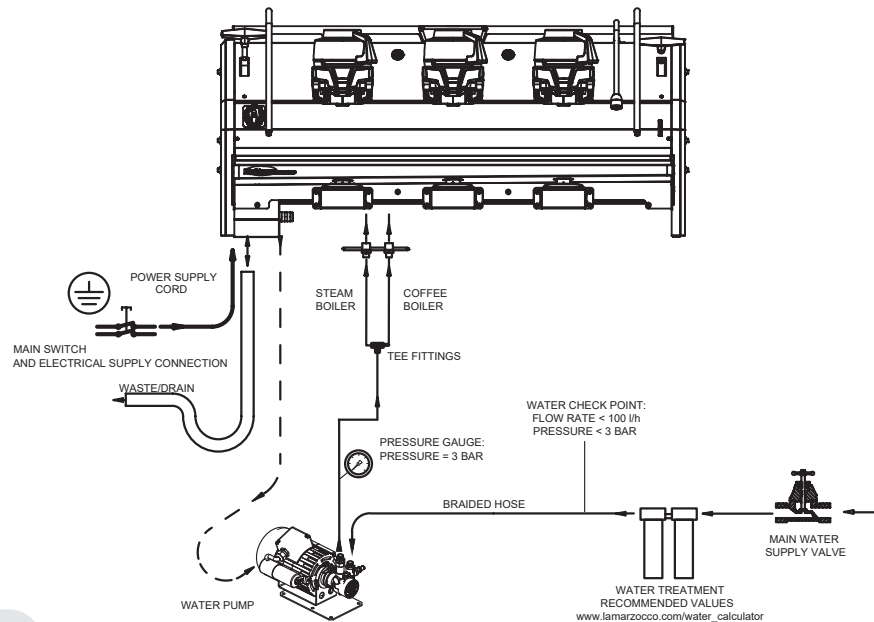

Fig. 3 - Installation guide - type 1

Pressure higher than 3 bar
Flow rate higher than 100 l/h

Installation of the pressure reducer (set to 3 bar with a flow rate of at least 100 l/h) immediately after the water treatment system, upstream of the tee.

Water treatment system + pressure reducer, reducing the flow rate within the recommended range NEVER LESS THAN 100 l/h.

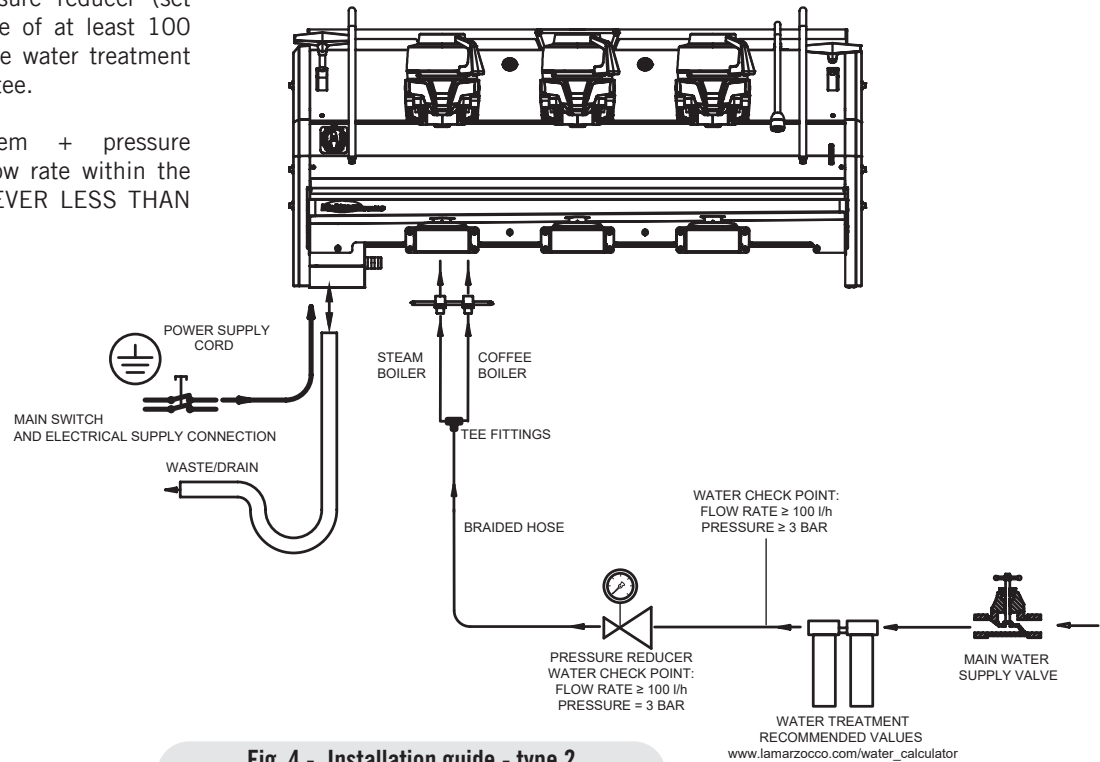

Fig. 4 - Installation guide - type 2

Pressure higher than 3 bar
Flow rate lower than 100 l/h

Installation of the pressure reducer (set to 3 bar) immediately after the water treatment system, upstream of the rotary pump.

Installation of the rotary pump (set to 3 bar) immediately after the pressure reducer, upstream of the tee.

Enter the programming menu and enable the second pump.

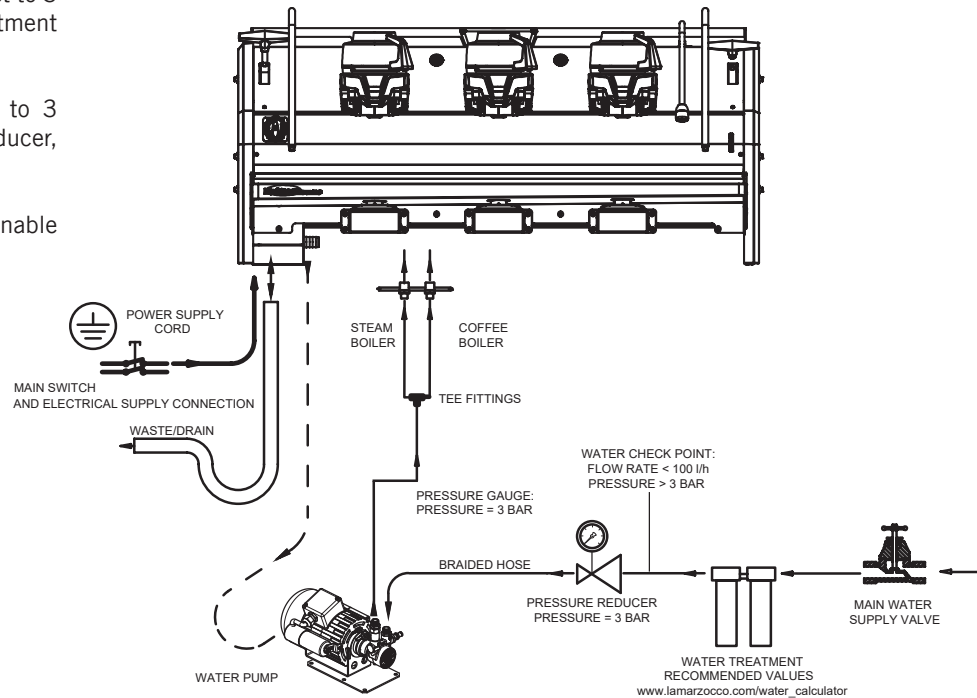

Fig. 5 - Installation guide - type 3

2) Accessories

In order to proceed with installation, it is necessary that the following are available:

- Pipes carrying drinking water with a 3/8" G (BSP) end connection; (3/8" Compression for USA and Canada)
- Electrical Supply according to the specification of the espresso machine purchased:
- Single/Three phase 220VAC - 50/60 Hz electrical connection with ground, protected socket and approved interlock switch
- Single phase 200VAC - 50/60 Hz electrical connection with ground, protected socket and approved interlock switch
- Three-phase, 380VAC - 50 Hz electrical connection with neutral + ground, near the bench on which the machine is installed and terminating in a suitable protected fivepole socket equipped with an approved interlock switch
- Waste water drain system.

3) Water test kit

In order to enable you to check if your water supply is within the suggested ranges, La Marzocco machines will be equipped with two units of a quick water test kit (see image below) including 6 test-strips and instruction cards.

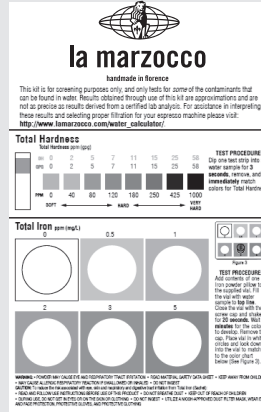

The parameters that you can measure are Total Hardness, Total Iron, Free Chlorine, Total Chlorine, pH & Total Alkalinity, Chlorides.

Ideally, you should perform a test on the water BEFORE the water treatment system and again AFTER the water system in order to verify if this is actually matching our suggested ranges.

Once the test has been performed, learn which treatment system is most appropriate for your particular water supply by filling out the online water calculator on our website: LA MARZOCCO WATER CALCULATOR (http://www.lamarzocco.com/water_calculator/).

4) Flowmeter safety removal

Before switch on, remove the clamp from the flowmeter located inside the machine, as indicated by the adhesive label applied on the main switch. Also remove the label from the main switch.

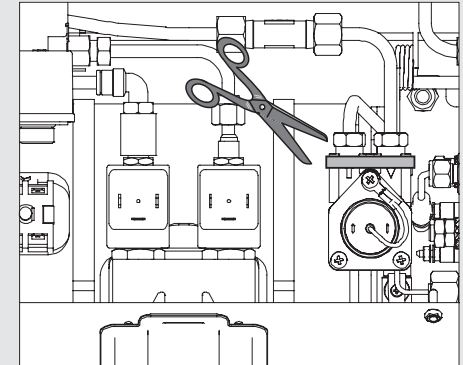

5) Water supply connection

In order to connect the machine up to the water mains proceed according to the indications given in the chapter about Installation and in compliance with any local/national safety standards of the location in which the machine is being installed.

The equipment is to be installed with adequate backflow protection to comply with applicable federal, state, and local codes.

To guarantee a correct and safe functioning of the machine and to maintain an adequate performance level and a high

quality of the beverages being brewed it is important that the incoming water be of a hardness greater than 7°f (70ppm, 4°d) and less than 10°f (100ppm, 6°d), pH should be between 6.5 and 8.5 and the quantity of chlorides be less than 30mg/l . Respecting these values allows the machine to operate at maximum efficiency. If these parameters are not present, a specific filtration device should be installed, while always adhering to the local national standards in place regarding potable water.

Then connect the inlet of the water filter/softener (if present) to the drinking water supply using one of the supplied stainless steel braided hoses. Before connecting the filter to the water pump, flush the water supply line and the filtration system in order to eliminate any residual particles which could otherwise get stuck in taps or valves thus preventing them from working properly. Connect the water supply connection of the espresso machine to the water pump outlet using one of the supplied stainless steel braided hoses. Then connect the water pump inlet to the water filter/softener outlet (if present).

Note: The water pump is a differential pressure volumetric pump and has been designed to be used exclusively with cold water. Make sure that water is always present while the pump is operating,

otherwise air can be introduced into the brew boiler causing an undesirable condition and the pump can be damaged.

6) Electrical connections

a) Power supply cord

- This is the main power supply cable that provides power to the entire espresso machine. There are different types of cable based upon the electrical requirements of the espresso machine purchased:

- 200/220VAC 1 Phase 3-core cable with 4/6/10mm² cross section or AWG 12/10/8 for 2,3 4 group versions, secured to espresso machine via a strain relief connector

- 220VAC 3 Phase 4-core cable with 4 mm² cross section for 2 , 3 and 4 group versions, secured to espresso machine via a strain relief connector

- 380 VAC 3 Phase 5-core cable with 2.5mm² cross section for 2, 3 and 4 group versions, secured to espresso machine via a strain relief connector.

b) Water pump motor power cord

This is the power supply for the water pump motor. The internal electronics will switch the pump motor on when needed.

- 3-core cable with 1.5 mm² cross section or 3-core AWG 16 (for UL version) secured to espresso machine via a strain relief connector.

c) Quick connection between the water pump and the espresso coffee machine

The electrical connection must be made through the use of the connectors, as shown in the following figures:

- View of the connectors;

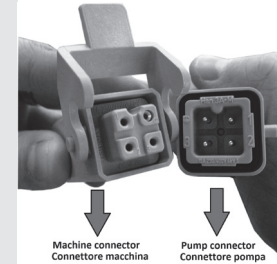

- Cable connection;

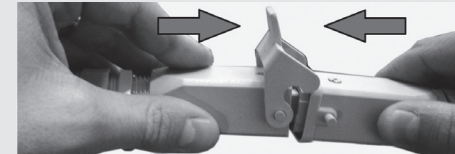

- Cable tightening;

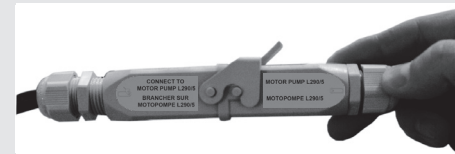

7) Waste water drain connection

The espresso machine drain is to be connected by means of the included reinforced plastic tubing. Connect one end of the reinforced plastic tubing to the drain hose connection on the left side of the espresso machine, secure with included hose clamp. Connect the other end to a suitable waste water collection system.

In case such a system is not available, drained liquids may be collected in a suitable bucket and any necessary drain pipe extensions shall be made using steel-lined PVC tubing and suitable hose clamps.

Water specifications table

		Min.	Max.
T.D.S.	ppm	90	150
Total Hardness	ppm	70	100
Total Iron (Fe ⁺² /Fe ⁺³)	ppm	0	0,02
Free Chlorine (Cl ₂)	ppm	0	0,05
Total Chlorine (Cl ₂)	ppm	0	0,1
pH	value	6,5	8,5
Alkalinity	ppm	40	80
Chloride (Cl ⁻)	ppm	not more	30

N.B.: Test water quality (the warranty is void if water parameters are not within the range specified in the section “installation”)

4. Machine Operation and Coffee Preparation

1) Starting the espresso machine

a) Filling the boilers with water

Once the installation procedures have been completed, it is necessary to fill the boiler tanks with water. Complete the following procedure to properly fill the boiler tanks:

• Coffee boiler

The water flows inside the coffee boiler directly, as soon as the water system and water filter/softener taps (if present) are opened. Since the inflow of water will compress the air in the boiler it will be necessary to remove or “bleed” the air from the coffee boiler.

All air must be removed in order to completely “saturate” the coffee boiler/group assemblies.

To remove the air from the boiler, or “bleed the groups”, it will be necessary to remove the plastic cap and the handle from the top of the group.

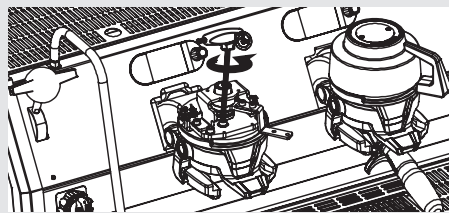

Loosen the bleed screws one at a time to allow air to escape until water flows from below the screw head. Tighten the screw to stop the water from flowing. Over tightening can cause damage to the sealing washer and the group cover. Repeat this procedure on all groups.

• Steam boiler

Turn the main switch to position “1” or ON, then push the encoder knob for three seconds and the automatic steam boiler level function will be switched on, activating the auto-fill solenoid valve and the motor pump. This will fill the steam boiler to a predetermined level and will shut off when full.

Note: Air inside the steam boiler may build up pressure (which may be detected through the pressure gauge).

Once the pump stops, check the display, the message “Coffee Boiler Filled?” should be displayed. Push the Encoder Knob to confirm that the preceding procedures are complete.

The installation is now complete and the espresso machine should be heating to operating temperatures.

2) Waiting for the espresso machine to heat to operating temperature

During this time, it may happen that the pointer of the coffee boiler pressure reaches as high as 14-15 bar. This may happen anytime that the heating element is in the “on” condition. In this case, it is necessary to adjust the expansion valve (see the picture below about the three coffee boiler expansion valves) in such a way that the pressure never exceeds 13 bar.

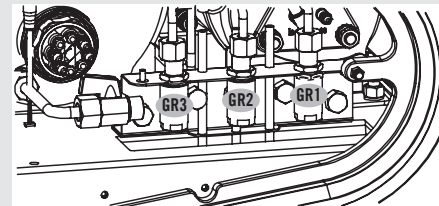

In normal operating conditions, the coffee boiler pressure transducer, while brewing, can read anywhere from 0-12 bar when brewing.

The steam boiler pressure is visible through a pressure gauge placed inside the machine, behind the control and the 1st group.

When the steam boiler reaches operating temperature, the light on the Tea dispense button will switch on.

3) Brewing after first installation

Once the first installation procedures are finished, before proceeding with brewing coffee, hot water and steam, please follow these steps:

- Engage the portafilters by inserting them into each group, brew water through each group for at least two minutes.
- Being careful to avoid burns, turn on each steam wand for at least one minute.
- Turn on the hot water valve for the time necessary to allow the following quantities of water to be brewed:
 - At least 1 liter for a 1/2 group machine
 - At least 2 liters for a 3 group machine

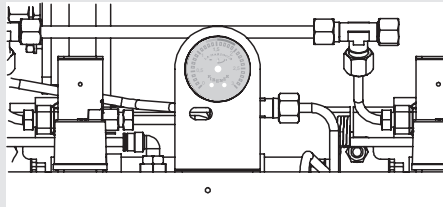

4) Installing the portafilters

Install the portafilter(s) by inserting them into the group and rotate the handle from left to right. When the portafilters are inserted properly, you can move the electronic Brew Paddle Lever to start the flow of water through the portafilter. You should allow hot water to pass through the empty portafilter(s) for a few seconds each time, in order to pre-heat the portafilter.

Note: It is important to leave the portafilters installed in the espresso machine when not in use. The portafilter must remain heated for the brew process to function correctly.

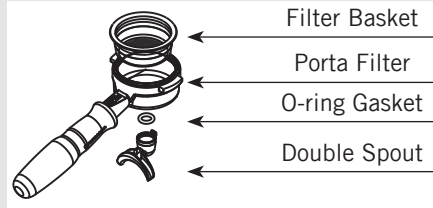

5) Brewing coffee

It is now possible to remove one of the portafilters to make an espresso beverage through the manipulation of the pressure to your taste.

The Strada Electronic Paddle is an formidable appliance for making espresso beverage that could develop extraction water pressure from 0 to 12 bar as you go.

Press down on the ground coffee with the supplied tamper and install the filter holder to the bottom of the group. Move the paddle to begin the brewing process. As soon as you start to turn the lever placed on top of the group the magnetic drive gear pump will pushing water into the portafilter.

By turning the lever of the Electronic Paddle it is possible to vary the speed of the gear pump, as much it will be turned as faster the pump will go.

Note: Some baristas suggest flushing the group with water to remove remaining coffee oil or particles. Some flush after every shot. Experimentation and practice is suggested to establish the best possible procedure for brewing coffee.

6) Water pump

Whenever you are brewing coffee, and you can adjust the pump pressure by turning the by-pass screw (below the plug located on the side to which the pump power supply is connected) clockwise to increase and counter-clockwise to reduce pressure. Adjust pressure only when at least one group is brewing coffee.

7) General notes for coffee preparation

The portafilters must remain heated since they are at the lowest position of the group itself, and they are partially isolated due to the rubber gasket between them. This can be accomplished by leaving the portafilters installed in the machine when not in use. The portafilters may also be actively heated. This procedure may be carried out by brewing some hot water

through the portafilter then turning off the water flow, before making coffee. We recommend removing the spent coffee puck directly after brewing.

The size of the coffee granules is extremely important in preparing a good cup of coffee, other than the type of coffee mix used, quite obviously. The ideal grinding can be determined by making various coffees using the amount of ground coffee that you would normally use for each cup (we recommend at least 6-7g). The best grinding is that which allows coffee to flow out from the filter holder spouts neither too slowly (drop by drop) nor too quickly (quick light brown flow). A general rule is that a double dose should dispense approximately 25cc or 2 fluid oz. of espresso in approximately 25 seconds.

8) Cup Warmer

WARNING

The Cup Warmer is at elevated temperature. Temperature over 125°F / 52°C can cause severe burns instantly or death from scalding.

Press Cup Warmer Button for enabled or disabled the cup warmer. This function

work in two modes continuous or timed (see the Software Programming Manual for further instructions).

Cup Warmer Button

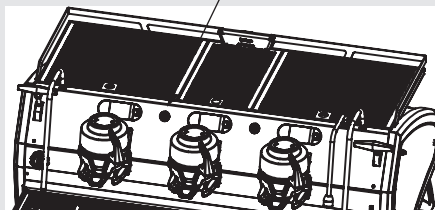

9) Autoclean and Autopurge (only for version with Straight-in)

If the autoclean function is enabled in the menu, steam will be delivered by the group with a delay of 2 seconds form portafilter removal.

If the autopurge function is enabled in the menu, hot water will be delivered by the group with a delay of 2 seconds form portafilter removal.

If the autoclean and autopurge functions are both enabled in the menu, steam and then hot water will be delivered by the group with a delay of 2 seconds form portafilter removal.

10) Activation of the rinse function (only for version without Straight-in)

The rinse function is activated by operating the lever shown in figure, turning it from

the dispensing position to the deactivation position within 1 second. The machine will dispense hot water for a certain number of seconds (the default setting is 4 seconds, but this can be changed to access the programming menu).

Group activation Paddle

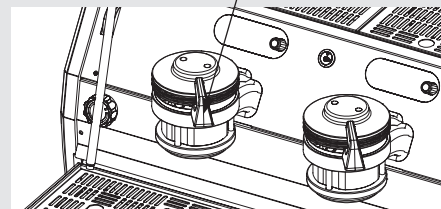

5. Dispensing Steam and Hot Water

1) Steaming milk or other liquids

In order to allow for any condensed water in the wand to be released ALWAYS allow some steam to be discharged by turning on the valve before inserting the steam wand into the pitcher of liquid to be heated.

Dip one of the 2 steam wands (item 10, page 5) which are connected to the steam valve, into the liquid to be heated. Move the steam wand lever gradually until steam comes out at the end of the wand.

The steam will transfer heat to the liquid raising its temperature up to boiling point. Be careful not to allow liquid to overflow in order to avoid severe burns.

In order to prevent the heated liquid from being sucked back into the steam boiler it is recommended before using the wand that you purge the steam valve and steam wand by opening the valve for a few seconds to allow steam to escape to the atmosphere from the end of the steam wand. Failure to do so can cause the heated liquid to transfer from the heated liquid container to the steam boiler

(via vacuum created from cooling parts). This condition is undesirable and can cause contamination in the steam boiler. After use remember to purge the wand by opening the steam valve for a few seconds, and then clean the outside of the wand itself with an appropriate cloth.

In order to prepare milk for making cappuccino with the right amount of foam, go through the following steps:

- After purging the steam wand place the container half-full of milk underneath, carefully open the steam valve and raise the container so as to bring the wand end to a point just below the surface of the milk; at this point, move the container up and down just enough to dip the nozzle end in and out of the milk until you get the right amount of foam, bring the temperature of the milk almost up to 149/158°F or 65/70°C. You can then pour this milk into a cup containing warm espresso and you will end up with a fresh cup of cappuccino.

2) Preparing tea and other hot drinks

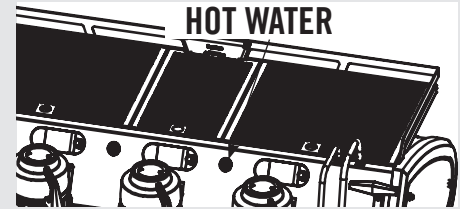

You may dispense hot water by using the fixed nozzle (item 5 page 5). To dispense hot water, press the tea water button.

This button commands the hot water delivery.

The temperature of the water may be adjusted by adjusting the mixing valve.

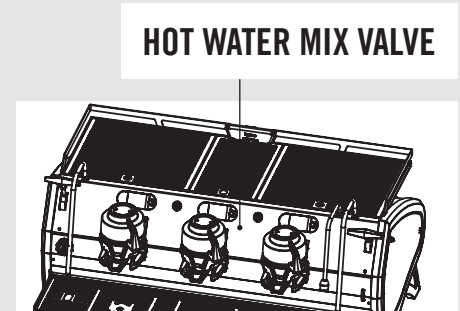

6. Maintenance and Periodic Cleaning Operations

WARNING

If the above-mentioned instructions are not adhered to the manufacturer cannot be held responsible for damage to persons or things.

WARNING

In order to prevent cracks or leakage: do not store or install the coffee machine in places where temperature may cause water in boiler or hydraulic system to freeze.

WARNING

The machine is intended to be permanently connected to fixed wiring, and it is advisable that a residual current device (RCD) with a rated residual operating current not exceeding 30mA is installed.

WARNING

The machine must be installed so that qualified technical personnel can easily access it for eventual maintenance.

WARNING

The machine must not be dipped in, nor splashed with, water in order to clean it. For cleaning operations, please follow the instructions listed below very carefully.

WARNING

Do not remove the filter holder while relative group is brewing hot liquids.

The Coffee Boiler contains water at elevated temperature. Water temperature over 125°F / 52°C can cause severe burns instantly or death from scalding.

WARNING

This machine is for professional use only and should be installed in locations where its use and maintenance is restricted to trained personnel.

WARNING

Jets of water should not be used to clean the machine, nor should it be placed where water jets are used.

WARNING

When cleaning the display, do not use alcohol or overly aggressive chemical reagents.

1) Cleaning groups and drain wells

- Put a tablespoon of detergent powder for coffee machines into the blind filter, supplied with the machine, and tighten it onto the group you want to clean by using a normal filter holder.

- Turn the Paddle Valve on and off approximately 10 times (10 seconds intervals) on each group.

- Rinse the group using a normal filter, by running hot water through it several times.

2) Cleaning filters

- Put 2 or 3 teaspoons of detergent powder for coffee machines in about 1/2 a litre of water inside a heat-resistant container and boil.
- Dip filters in the boiled solution and leave them fully submerged for about 30 minutes.
- Rinse thoroughly with clean water and run hot water through one group several times with the filters in place.
- Make one cup of coffee and discard in order to remove any unpleasant flavor.

3) Cleaning filter holders (portafilters)

Using the proper cleaning tool (brush) wash the filter holders under hot water, a neutral detergent may also be used. For extraordinary cleaning see the Portafilter Manual.

4) Cleaning the drain collector

Remove the drain tray grill at least twice a week and clean, pull out the water drain collector and clean it thoroughly. Inspect and clean also the drain box and remove any leftover grounds.

5) Cleaning the body

Wipe the stainless steel surfaces with a soft, non-abrasive cloth in the direction of the glazing marks, if any. Do not use any

alcohol or solvents whatsoever on painted, imprinted, or plastic parts in order not to damage them. Clean the side panels using a soft cloth. Clean only with a damp soft cloth or possibly soaked in warm water and mild soap.

6) Cleaning the hot water and steam nozzles

Steam nozzles must be cleaned immediately after use with a damp cloth and by producing a short burst of steam so as to prevent the formation of deposits inside the nozzles themselves, which may alter the flavor of other drinks to be heated. Hot water nozzles must be cleaned periodically with a damp cloth.

7) Cleaning the diffuser screen

- Due to filter holder discharge operations (subsequent to coffee brewing), a certain amount of coffee grounds may slowly build-up on and obstruct, even partially, the diffuser screen. To clean it, you must first remove it by unscrewing the diffuser screw.

- Put 2 or 3 teaspoons of cleaning detergent for coffee machines in about 1/2 a litre of water inside a heat-resistant container and boil.

- Place the diffuser screen(s) and diffuser screw(s) in the solution and leave them fully submerged for about 10 minutes.

- Rinse thoroughly with clean water. Install and run hot water through each group several times with the screen installed.

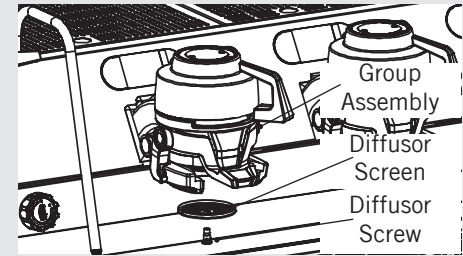

8) Cleaning the portafilter group

After pressing the straight-in release lever, it is possible to use a non-abrasive soft cloth to clean the portafilter support. Do not use aggressive solvents on varnished parts or plastic parts to avoid damage. Clean the cover panels using a soft cloth. Only clean with a wet cloth or with a cloth soaked with warm water and neutral soap.

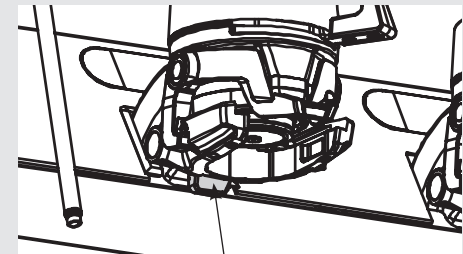

Straight-in Release Lever
(if present)

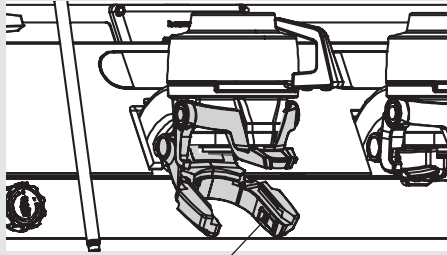

Portafilter Support
(if present)

9) Cleaning the display

Clean only with a damp soft cloth or possibly soaked in warm water and mild soap. Do not use alcohol or products containing alcohol or overly aggressive chemical reagents that could damage the components.

10) Water Filter/Softener

Please see the documentation accompanying the water filter/softener for proper operating and cleaning instructions.

If the machine has not been used for more than 8 hours or, in any case, after long periods of being idle, in order to use the machine to its full potential it is necessary to perform some cleaning cycles before brewing beverages as follows:

- **Groups:** with the portafilters engaged in the groups brew water through each for at least two minutes

- **Steam:** Being careful to avoid burns, turn on each steam wand for at least one minute.
- **Hot water:** Turn on the hot water valve for the time necessary to allow the following quantities of water to be brewed:
 - At least 1 liter for a 1/2 group machine
 - At least 2 liters for a 3 group machine
- **Steam boiler draining:** to activate this function you need to access the programming menu. Yearly, we recommend to fully drain the steam boiler by means of the specific drain cock located on the side of the boiler or under the boiler.

11) Depressurize the steam boiler

Press and hold the encoder knob to set the espresso machine to “OFF”, then push down the steam lever in order to depressurize the steam boiler.

IMPORTANT

If the machine is not going to be used for long periods of time, it is advisable to follow these safety indications:

- Disconnect the machine from the water mains or interrupt the water connection via a mains tap.
- Disconnect the machine from the electrical mains.

Cleaning frequency

Daily

- Portafilter
- Filter
- Diffuser screen
- Diffuser screw
- Steam wand (just after use)
- Drain grille

Weekly

- Drain Box

Monthly

- Cleaning the hot water nozzle

7. De-commissioning and Demolition

1) De-commissioning and demolition

Start by setting the main switch to the “0” or OFF position.

Disconnecting from the power outlet

Disconnect the espresso machine from the electrical network by switching off the associated circuit breaker or circuit protection device. Remove the power supply cord from the power connection. Remove the Pump Motor Power Cord from the water pump motor.

Disconnecting from the water system

Shut off the water supply by closing the specific tap located upstream of the water filter/softener inlet. Disconnect the water pipe at the water filter/softener inlet.

Remove the hose connecting the espresso machine to the water pump. Remove the reinforced plastic tubing on the drain connection.

At this point, the machine may be removed from the bar, being very careful not to drop it or squash your fingers.

The machine is made out of various materials and therefore, if you do not intend to put it back in service, it must be taken to a special disposal company which will select the materials which can be recycled and discard the others.

Current regulations make it illegal to discard such machine by leaving it on public grounds or on any private property.

Recycling notice: Warning for the protection of the environment.

Used Electrical and electronic waste contains hazardous but also valuable and scarce materials which should be recovered and recycled properly. We kindly ask that you contribute to the protection of the environment and natural resources by delivering used equipment to the relevant recycling locations if such locations are available in your country.

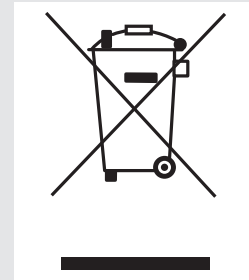

8. Mandatory Maintenance and Check-up Operations

These operations are in addition to the Maintenance and Periodic Cleaning Operations as specified in Chapter 6.

The following maintenance and check-up operations could be carried out by a qualified technician.

The time required for the periodic maintenance is determined by the quantity of daily work and/or coffee consumption.

N.B. These periodic maintenance operations are not covered by warranty.

EVERY THREE/FOUR MONTHS

- | | | | |
|---|---|--|--|
| <ul style="list-style-type: none"> ▪ Replace group gaskets ▪ Replace diffuser screens ▪ Check filter baskets and springs condition ▪ Clean auto-fill probe ▪ Check vacuum breakers for proper operation ▪ Check fittings and valves for leaks | <ul style="list-style-type: none"> ▪ Inspect drain box and hose for leaks or clogs ▪ Check flow rate for each group ▪ Check brewing pressure ▪ Check all buttons for proper operation ▪ Check expansion valve operation ▪ Check steam valves for proper operation | <ul style="list-style-type: none"> ▪ operation ▪ Check/note water hardnessm (Water quality must be within the range of parameters specified in the chapter on Installation, otherwise warranty is voided) ▪ Check doses consistency ▪ Test flowmeter's ohm value | <p>(ohm value is acceptable if greater than 1.8 K ohm, and less than 2.2 K ohm</p> <ul style="list-style-type: none"> ▪ Check straight-in piston for leaks under pressure (if present) <p>If ABR Model:</p> <ul style="list-style-type: none"> ▪ Run "scale test" |
|---|---|--|--|

EVERY SIX (in addition to the above)

- | | | | |
|---|--|--|--|
| <ul style="list-style-type: none"> ▪ Replace filter baskets ▪ Fit steam valve rebuild kit | <ul style="list-style-type: none"> ▪ Check group cap micro switches | <p>If ABR Model:</p> <ul style="list-style-type: none"> ▪ Calibrate scales | <ul style="list-style-type: none"> ▪ Check weight of precision portafilters |
|---|--|--|--|

EVERY YEAR (in addition to the above)

- | | | | |
|--|--|---|--------------------------------|
| <ul style="list-style-type: none"> ▪ Inspect solenoid valves ▪ Replace vacuum breakers ▪ Inspect expansion valve ▪ Inspect electrical wiring condition | <ul style="list-style-type: none"> ▪ Inspect boilers safety switches ▪ Replace over-pressure valve (safety valve) ▪ Accurate control of the tightness at 2,4Nm of each cable on | <ul style="list-style-type: none"> the terminal block. ▪ Inspect flowmeter impellers ▪ Replace bushings (if present) on straight-in lock systems ▪ Rebuild straight-in piston | <p>assemblies (if present)</p> |
|--|--|---|--------------------------------|

EVERY 3 YEARS (in addition to the above)

- Check the condition of the inside of boilers and if necessary rinse out with a proper cleaning product allowed for food and beverage appliances.
- Replace straight-in jaws systems (if present)

9. Precision Scale

WARNING
Handle with care maximum load
1Kg do not lift.

WARNING
The individual grid of the scale
is a fragile component, handle
and store with care.

WARNING
The height of the bottom tray is
fixed.

1) Use precautions

Remove the adhesive label with care; if needed, remove any adhesive residues from the surface using a neutral detergent.

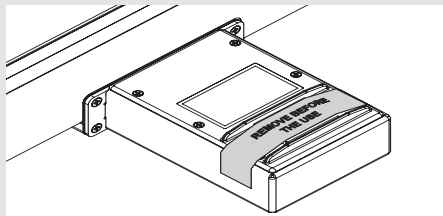

Don't spill water onto the scale box. If needed, gently remove it with an absorbent cloth. Should any water and/or dirt penetrate into the holes highlighted

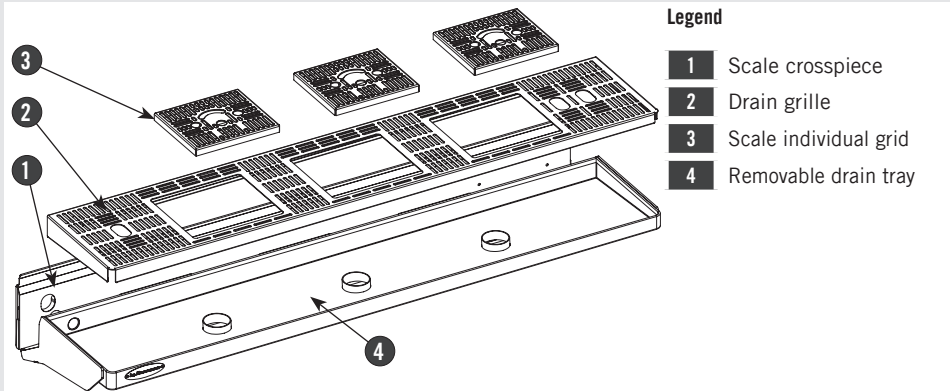

Legend

- 1 Scale crosspiece
- 2 Drain grille
- 3 Scale individual grid
- 4 Removable drain tray

Fig. 6 - Precision scale - 2 and 3 brewing groups

in the figure below, gently clean and dry them with an absorbent paper cloth. Dirt build-up or water stagnation may prevent the scale individual grid from properly settling into place.

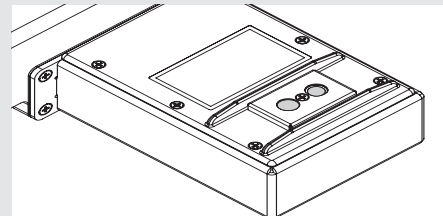

The weighing system in static conditions (*) has a rated accuracy of $\pm 0.5g$. For correct operation, make sure that:

- Maintenance is performed properly, by an authorized person and in the manner prescribed in this manual;
- Please use the machine according to the instructions specified in this manual;
- Please make sure the machine is installed on a level and firm counter;
- Please make sure the power supply is stable and without electrical noises.

The weighing stage is inherently delicate, in fact it is affected by:

- Vibration of the bench caused for example by other devices;
- Machine vibrations caused, for example, by the use of the adjacent group.

(*) Static weighing means weighing an object whose weight is fixed during the entire weighing.

The machine is not a weighing device certified for legal weighing.

- The weighing system is a precision device that requires a lot of caution in terms of use, cleaning and maintenance.

- Should the main grid or tray be removed, ensure not to hit the load cells during the disassembly and reassembly operations.

- To proceed with the weighing of the filter holder either empty or filled with coffee powder, place it as shown below:

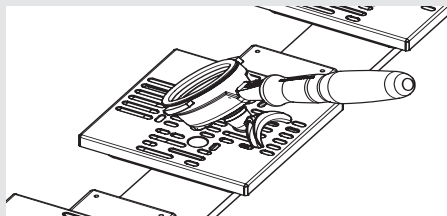

- Use only original La Marzocco filters and filter holders, identified by the following symbol:



- Use only filter holders with double spout;

- Do not place on the scale objects weighing more than 1kg;

- Never load more than 1 kg, to prevent any damage to the scales;

- Use the high precision scale with care, avoid shocks, falling objects and sudden load peaks;

- Any object to be weighed must be placed correctly on the scales grid.

2) Cleaning

- The cleaning of the “individual grids” must be performed with care, without overloading the cells;

- For proper weighing of the filter holder, make sure the grid is clean and dry;

- To avoid contact with dirt before placing the filter holder, clean and dry the grid;

- Please be careful during the cleaning procedures to avoid the water dripping on the scale and its electrical components;

- Don't wash the scale individual grids in a dishwasher; wash them manually instead, then immediately dry them.

If you wash the grid under a strong water flow, remove the magnetic support highlighted in the figure (just pull to detach the magnets). Make sure that the magnets are always dry and clean.

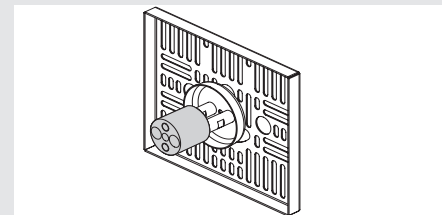

- To clean the drain tray you need to remove the individual grids (part 3, figure 5) first, then the drain grille (part 2, figure 5) and finally the tray (part 4, figure 5). Make sure not to hit the load cells during the disassembly and reassembly operations.

3) Removing the electronic box

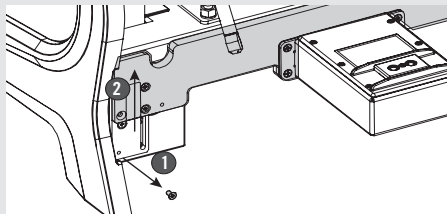

To remove the electronic box you need to remove the lower front panel, unscrew and remove the lower screws **1**, loosen the upper screws **2** without removing them and move the scale crosspiece up. Now you can access the electronic box or remove it.

10. Straight-in (if present)

1) Installing the portafilters

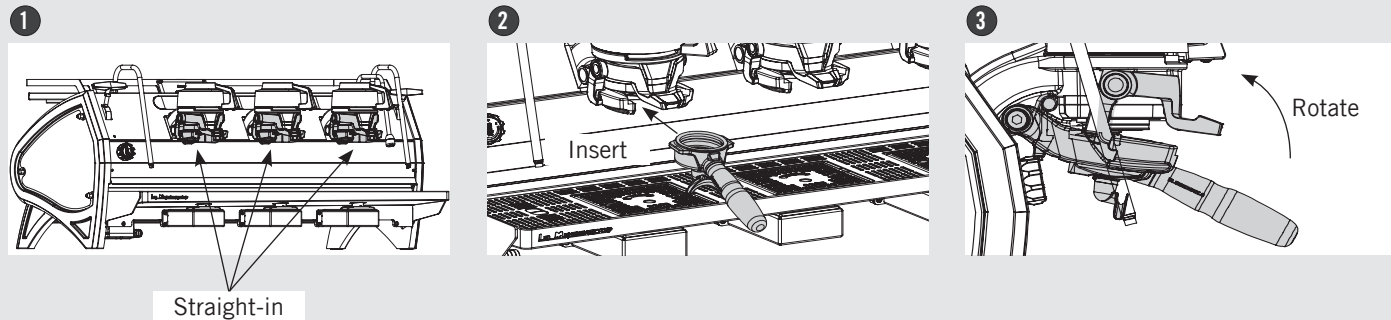

2) Removal the portafilters

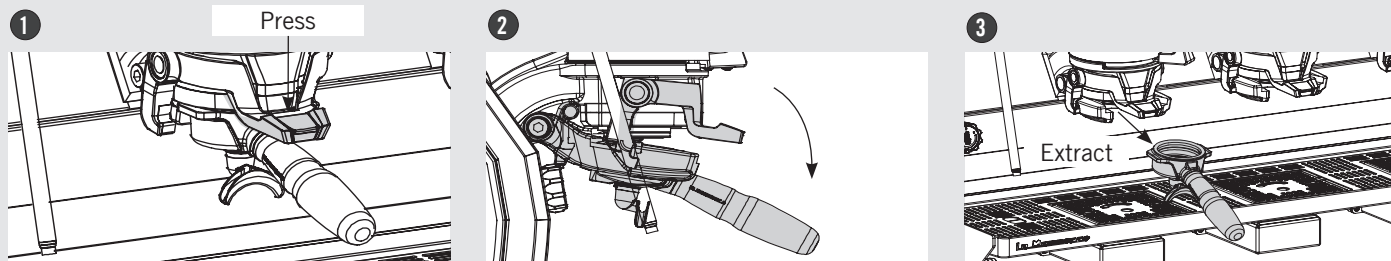

11. Software Programming Guide

“Barista” Programming

95.5°C 8.7b 126.6°C
30.0g in 35s
0g 10g 20g 30g 40g 50g 60g
01/15
page 38



93.2°C 9.0b 126.5°C
Brew Coffe
Backflush Group
Power Options
Machine Settings
Manage Profiles
page 46



93.2°C 9.0b 126.5°C
AV Brewing
Settings
page 48



93.2°C 9.0b 126.5°C
Water Dose
Settings
page 50



93.2°C 9.0b 126.5°C
Steam Flush
ENABLED
page 53



93.2°C 9.0b 126.5°C
Flush
ENABLED
page 54



“Barista” Programming

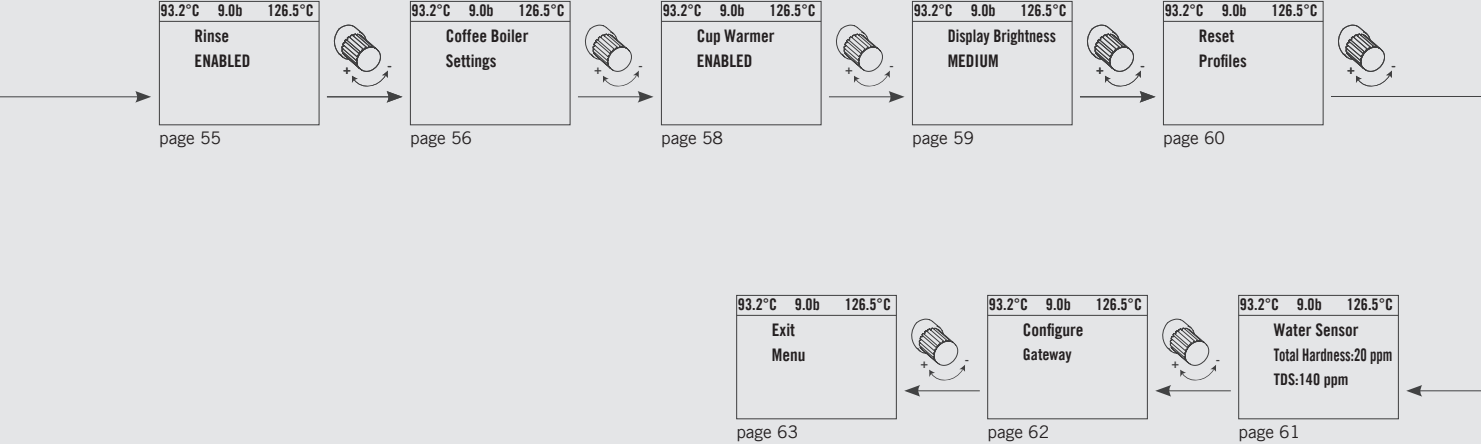

“Technical” Programming

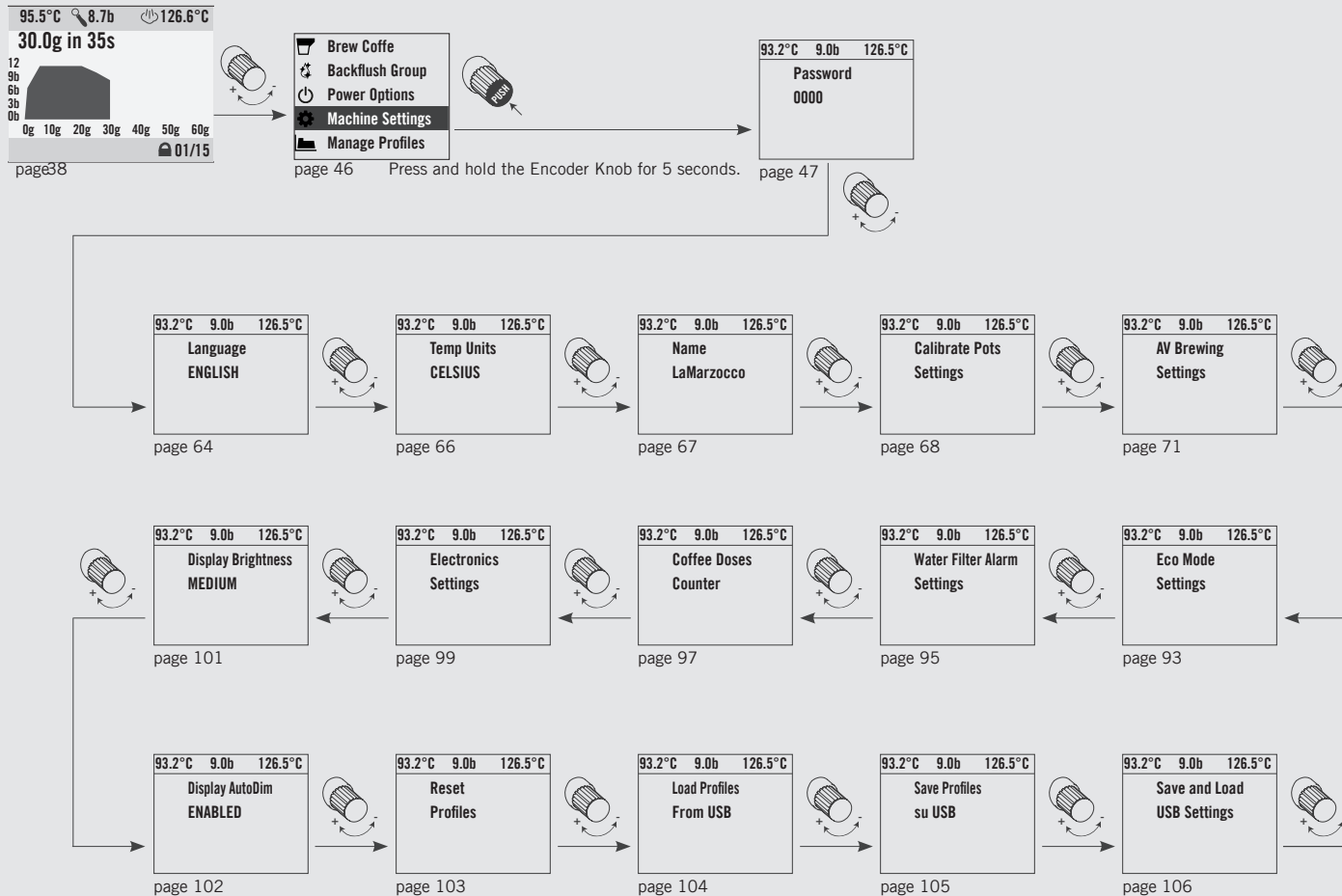

“Technical” Programming

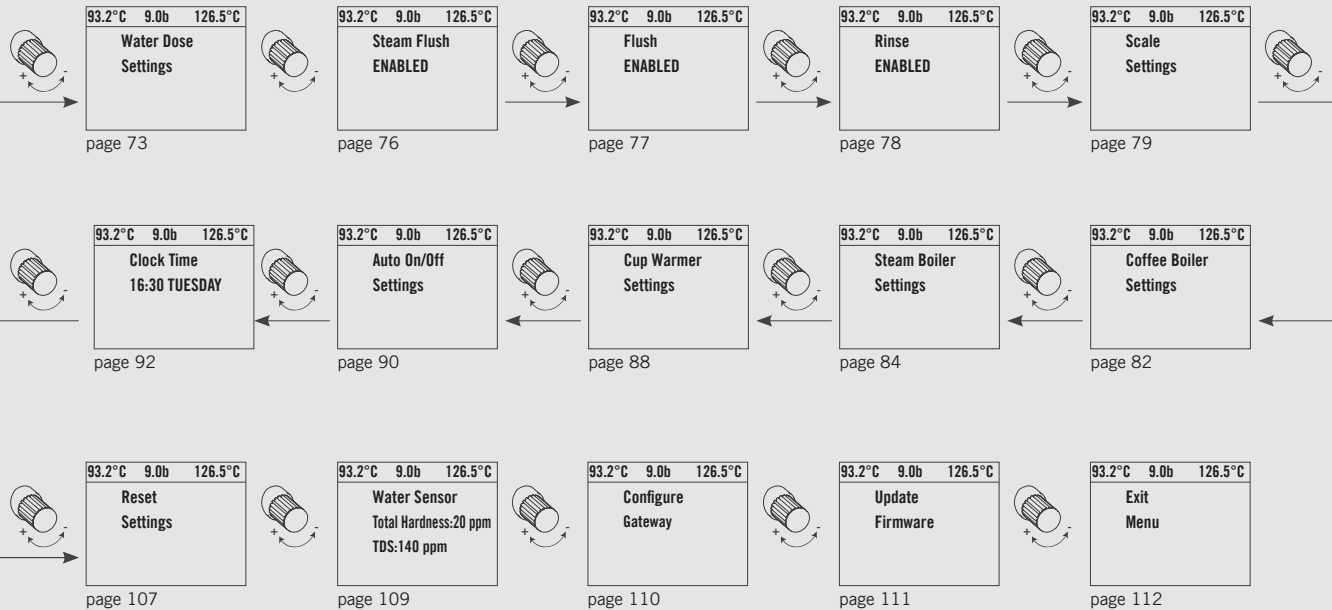

Programming Display

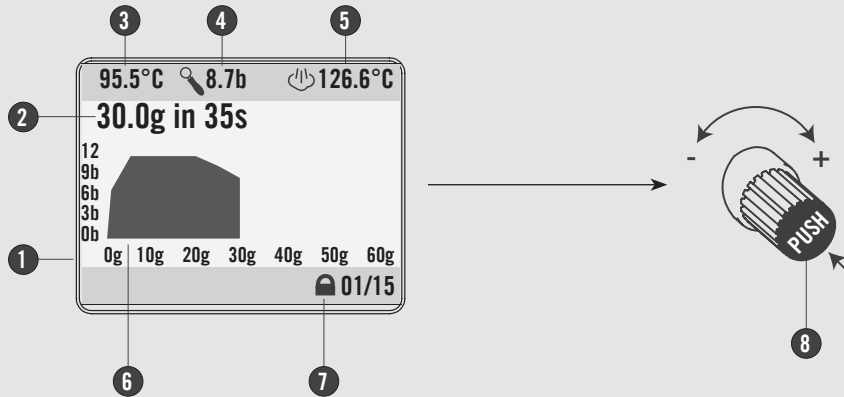

- 1 Graphic programming display with Encoder
- 2 Doses and delivery time
- 3 Coffee boiler temperature
- 4 Delivery pressure (bar)
- 5 Steam boiler temperature
- 6 Dispensing graph
- 7 Open/locked profile view
- 8 Encoder knob: Rotating to the right increases the value. Rotating to the left decreases the value. Pressing allows to browse the software menu, to access the functions or to confirm the first installation.

The display enables the operator to interact with the espresso machine to visibly change parameter values. The display also provides valuable information to the operator.

There are several warnings that can be displayed to alert the operator of an unusual condition or a fault. Additionally, simple messages are displayed alerting the operator that an action has been started or that a process needs to begin.

Turning the Espresso Machine On

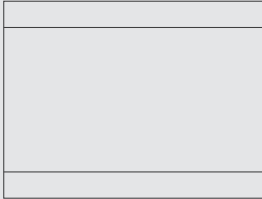

The following is the procedure for turning on the power to the espresso machine.

- Please follow the procedures carefully to avoid any damage to the espresso machine.

- Proceed checking for water connection to the espresso machine.
- Proceed making sure you have filled the boilers.

Display	Operating Procedure
	<ol style="list-style-type: none"> <li data-bbox="348 615 794 645">1 Turn the Main Switch to the 1 position. <div data-bbox="888 587 1113 681" style="display: inline-block; vertical-align: middle;"> </div> <li data-bbox="348 747 1466 777">2 The espresso machine is now on; temperature is displayed in red to indicate that warm-up is under way. <p data-bbox="388 828 1526 928">NOTE: Ensure all air is removed from the group prior to starting the espresso machine. This only needs to be completed once during the initial setup or when water is drained from the coffee boiler. Instructions for bleeding the groups of air can be found in the Installation Guide.</p>

WARNING

HAZARDOUS VOLTAGE DISCONNECT FROM POWER SUPPLY BEFORE SERVICING

Play Recorded Profiles

Brew Coffee

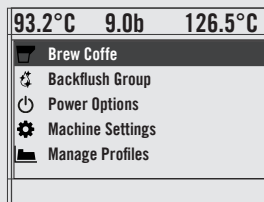

- This parameter allows the operator to select the type of coffee brewing.
- This is the function for brewing the coffee in play recorded profiles mode.

Display	Operating Procedure
	<ol style="list-style-type: none"> 1 Press the Encoder Knob to access the menu.
	<ol style="list-style-type: none"> 2 Press the Encoder Knob to confirm the option.
	<ol style="list-style-type: none"> 3 Operate the Paddle for the electronic dispensing control to start brewing the coffee by replicating an already existing profile.

Brew Coffee

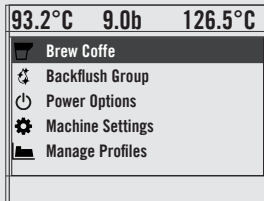

- This parameter allows the operator to select the type of coffee brewing.
- This is the function for brewing coffee in profile recording mode.

Display	Operating Procedure
	<p>1 Press the Encoder Knob to access the menu.</p>
	<p>2 Press the Encoder Knob to confirm the option.</p>
	<p>3 Operate the lever for the electronic dispensing control to start brewing the coffee in profile recording mode.</p>

Cleaning Cycles

Cleaning Cycles

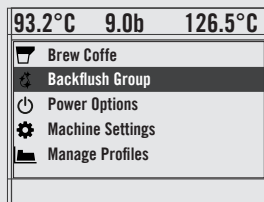

- This parameter allows the operator to carry out the washing of the coffee groups, in an automatic way, by running multiple cleaning cycles.
- This espresso machine has a group rinsing function (rinsing jets) integrated in the electronics.
- The rinsing procedure is provided to give

the operator more flexibility and freedom with regard to this operation.

- Do not perform the cleaning procedure when other groups are dispensing coffee.

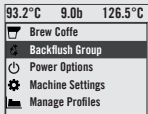
Display	Operating Procedure
 <p>93.2°C 9.0b 126.5°C</p> <p>Brew Coffe</p> <p>Backflush Group</p> <p>Power Options</p> <p>Machine Settings</p> <p>Manage Profiles</p> <p>93.2°C 9.0b 126.5°C</p> <p>Use the Paddle to Backflush</p>	<ol style="list-style-type: none"> <li data-bbox="310 618 816 642">1 Press the Encoder Knob to access the menu. <li data-bbox="310 747 1032 771">2 Operate the Electronic Paddle for activate the washing procedure.

Turning the Espresso Machine Off

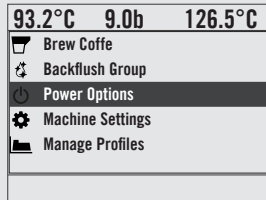

The following is the procedure for turning off power to the espresso machine.

- Please follow the procedures carefully to avoid any damage to the espresso machine.

- This machine has two off settings. One setting turns off all of the components in the espresso machine and the other turns off power to the complete espresso machine.

Display	Operating Procedure
	<ol style="list-style-type: none"> <li data-bbox="348 618 1158 647">1 The following is the procedure for safely turning off the espresso machine.
	<ol style="list-style-type: none"> <li data-bbox="348 751 868 780">2 Press the Encoder Knob to confirm the option.

⚠ WARNING ⚠

HAZARDOUS VOLTAGE DISCONNECT FROM POWER SUPPLY BEFORE SERVICING

Shut Down Procedures

Turning the Espresso Machine Off

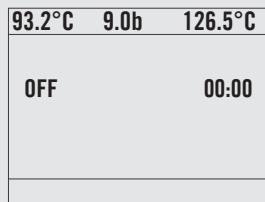

The following is the procedure for turning off power to the espresso machine.

- Please follow the procedures carefully to avoid any damage to the espresso machine.

- This machine has two off settings. One setting turns off all of the components in the espresso machine and the other turns off power to the complete espresso machine.

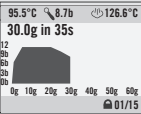
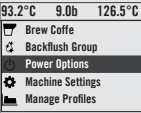
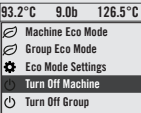
Display	Operating Procedure
  	<ol style="list-style-type: none"> <li data-bbox="310 617 1120 647">1 The following is the procedure for safely turning off the espresso machine. <li data-bbox="310 747 981 777">2 Rotate the Encoder Knob until the following display appears. <li data-bbox="310 877 968 907">3 Press the Encoder Knob until the following display appears. Press the Encoder Knob; the following will be displayed: You can turn off the group only, by selecting Turn Off Group <li data-bbox="310 1007 941 1037">4

WARNING

HAZARDOUS VOLTAGE DISCONNECT FROM POWER SUPPLY BEFORE SERVICING

Turning the Espresso Machine Off

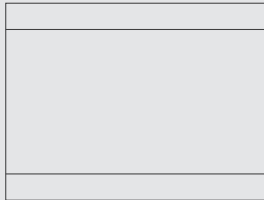

The following is the procedure for turning off power to the espresso machine.

- Please follow the procedures carefully to avoid any damage to the espresso machine.

- This machine has two off settings. One setting turns off all of the components in the espresso machine and the other turns off power to the complete espresso machine.

Display	Operating Procedure
	<p>5 This is the OFF setting used in the normal operating conditions.</p> <p>During servicing or other conditions that warrant it, the main switch should be turned to the OFF position.</p> <p>6 The espresso machine is off and display should be blank. It is important to follow this procedure when turning off the machine. Failure to do so can damage the electronics.</p> <div style="text-align: center;"> </div>

⚠ WARNING ⚠

HAZARDOUS VOLTAGE DISCONNECT FROM POWER SUPPLY BEFORE SERVICING

Accessing Programming Mode

Programming Mode

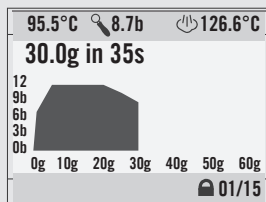

- To change the values of any parameter the operator must first enter into the programming mode.
- There are two levels within the programming mode that allow the programming of specific parameters.
- The two programming levels are as follows:
 - **Barista Programming** - The parameters contained within this level are ones the operator can change to affect the quality of the espresso. No password is required for access.
 - **Technical Programming** - The parameters contained within this level are ones the operator can change to affect the performance of the espresso machine.

Display	Operating Procedure
	<p>1 While the espresso machine is on, rotate the Encoder Knob until the following display appears.</p>
	<p>2 Press the Encoder Knob until the following display appears.</p>
	<p>Press the Encoder Knob to access the “Barista” programming menu.</p> <p>3 Press and hold the Encoder Knob. After about 5 seconds the “Technician” programming display will appear. (see point 5)</p>
	<p>4 This is the “Barista” programming level. To set the coffee boilers, to enable/disable the resistance of the cup warmer if present, and etc..</p>

Programming Mode

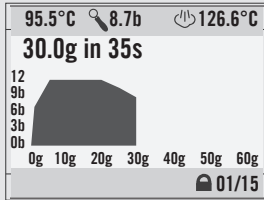

These parameters are set in the factory and their adjustment requires the intervention of a service technician. La Marzocco recommends that no changes are made at this level. The Technician Password is required for access.

Display	Operating Procedure
	<p>5 This is the “Technical” programming level. Using the Encoder Knob to move between the available parameters, press the Encoder Knob to confirm.</p>
	<p>You must scroll to the exit menu to exit the programming mode, or press the Encoder Knob for 2 seconds.</p>

“Barista” Programming

AV Brewing

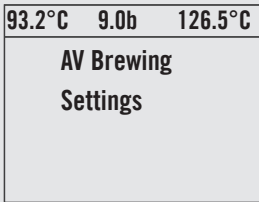

- This parameter allows the operator to program the amount of coffee (brewing amount) for each Selection Indicator.
- The brewing amount can be set in terms of time (sec.), pulses, mass or brewratio.
- Once programmed, the Selection Indicator remains lighted.
- It is possible to set the dose for both a short and a long shot on the same Selection Indicator.
- PULSE mode: control of doses in volume
- MASS mode: control of doses in mass
- BREW RATIO mode: ratio between the coffee powder and the weight of the drink

Display	Operating Procedure
<p>93.2°C 9.0b 126.5°C</p> <ul style="list-style-type: none"> Brew Coffee Backflush Group Power Options Machine Settings Manage Profiles 	<p>1 When the espresso machine is turned on, rotate the Encoder Knob until the following display appears.</p>
<p>93.2°C 9.0b 126.5°C</p> <p>AV Brewing Settings</p>	<p>2 Press the Encoder Knob to access the menu.</p>
<p>93.2°C 9.0b 126.5°C</p> <p>G1 AV Mode Settings</p>	<p>3 Press the Encoder Knob to access the menu.</p>
<p>93.2°C 9.0b 126.5°C</p> <p>G1 Pressure 9.0b</p>	<p>4 Press the Encoder Knob to access the menu, rotate the Encoder Knob to modify the value, press the Encoder Knob to confirm the desired value.</p>

AV Brewing

93.2°C	9.0b	126.5°C
AV Brewing Settings		

- This parameter allows the operator to program the amount of coffee (brewing amount) for each Selection Indicator.
- The brewing amount can be set in terms of time (sec.), pulses, mass or brewratio.
- Once programmed, the Selection Indicator remains lighted.
- It is possible to set the dose for both a short and a long shot on the same Selection Indicator.
- PULSE mode: control of doses in volume
- MASS mode: control of doses in mass
- BREW RATIO mode: ratio between the coffee powder and the weight of the drink

Display	Operating Procedure						
<table border="1"> <tr> <td>93.2°C</td> <td>9.0b</td> <td>126.5°C</td> </tr> <tr> <td colspan="3" style="text-align: center;"> G1 Mode MASSA </td> </tr> </table>	93.2°C	9.0b	126.5°C	G1 Mode MASSA			5 Press the Encoder Knob to access the menu, rotate the Encoder Knob to choose between PULSES , MASS and BREW RATIO , press the Encoder Knob to confirm the option.
93.2°C	9.0b	126.5°C					
G1 Mode MASSA							
<table border="1"> <tr> <td>93.2°C</td> <td>9.0b</td> <td>126.5°C</td> </tr> <tr> <td colspan="3" style="text-align: center;"> G1 Dose 50.0g </td> </tr> </table>	93.2°C	9.0b	126.5°C	G1 Dose 50.0g			6 Press the Encoder Knob to access the menu, rotate the Encoder Knob to modify the value, press the Encoder Knob to confirm the desired value.
93.2°C	9.0b	126.5°C					
G1 Dose 50.0g							
<table border="1"> <tr> <td>93.2°C</td> <td>9.0b</td> <td>126.5°C</td> </tr> <tr> <td colspan="3" style="text-align: center;"> G1 AV Mode Exit </td> </tr> </table>	93.2°C	9.0b	126.5°C	G1 AV Mode Exit			7 Press the Encoder Knob to quit the submenu.
93.2°C	9.0b	126.5°C					
G1 AV Mode Exit							
<table border="1"> <tr> <td>93.2°C</td> <td>9.0b</td> <td>126.5°C</td> </tr> <tr> <td colspan="3" style="text-align: center;"> AV Brewing Exit </td> </tr> </table>	93.2°C	9.0b	126.5°C	AV Brewing Exit			8 Press the the Encoder Knob to return to the “Barista” programming.
93.2°C	9.0b	126.5°C					
AV Brewing Exit							

“Barista” Programming

Water Dose

93.2°C	9.0b	126.5°C
Water Dose Settings		

- This parameter allows the operator to program the amount of water (brewing amount) for the hot water button.

Display	Operating Procedure						
<table border="1"> <tr> <td>93.2°C</td> <td>9.0b</td> <td>126.5°C</td> </tr> <tr> <td colspan="3"> <ul style="list-style-type: none"> ☑ Brew Coffe ⚙ Backflush Group ⚙ Power Options ★ Machine Settings ☰ Manage Profiles </td> </tr> </table>	93.2°C	9.0b	126.5°C	<ul style="list-style-type: none"> ☑ Brew Coffe ⚙ Backflush Group ⚙ Power Options ★ Machine Settings ☰ Manage Profiles 			<p>1 When the espresso machine is turned on, rotate the Encoder Knob until the following display appears.</p>
93.2°C	9.0b	126.5°C					
<ul style="list-style-type: none"> ☑ Brew Coffe ⚙ Backflush Group ⚙ Power Options ★ Machine Settings ☰ Manage Profiles 							
<table border="1"> <tr> <td>93.2°C</td> <td>9.0b</td> <td>126.5°C</td> </tr> <tr> <td colspan="3" style="text-align: center;"> Water Dose Settings </td> </tr> </table>	93.2°C	9.0b	126.5°C	Water Dose Settings			<p>2 Press the Encoder Knob to access the menu.</p>
93.2°C	9.0b	126.5°C					
Water Dose Settings							
<table border="1"> <tr> <td>93.2°C</td> <td>9.0b</td> <td>126.5°C</td> </tr> <tr> <td colspan="3" style="text-align: center;"> Water Dose CONTINUOUS </td> </tr> </table>	93.2°C	9.0b	126.5°C	Water Dose CONTINUOUS			<p>3 Press the Encoder Knob to access the menu, rotate the Encoder Knob to choose between CONTINUOUS or TIME, Press the Encoder Knob to confirm the option.</p>
93.2°C	9.0b	126.5°C					
Water Dose CONTINUOUS							
<table border="1"> <tr> <td>93.2°C</td> <td>9.0b</td> <td>126.5°C</td> </tr> <tr> <td colspan="3" style="text-align: center;"> Water Dose 15.0 s </td> </tr> </table>	93.2°C	9.0b	126.5°C	Water Dose 15.0 s			<p>4 Press the Encoder Knob to access the menu, rotate the Encoder Knob to modify the value, press the Encoder Knob to confirm the desired value.</p>
93.2°C	9.0b	126.5°C					
Water Dose 15.0 s							

Water Dose

93.2°C	9.0b	126.5°C
Water Dose Settings		

- This parameter allows the operator to program the amount of water (brewing amount) for the hot water button.

Display	Operating Procedure						
<table border="1" style="width: 100%;"> <tr> <td>93.2°C</td> <td>9.0b</td> <td>126.5°C</td> </tr> <tr> <td colspan="3" style="text-align: center;"> Water Long Dose 15.0 s </td> </tr> </table>	93.2°C	9.0b	126.5°C	Water Long Dose 15.0 s			<p>5 Press the Encoder Knob to access the menu, rotate the Encoder Knob to modify the value, press the Encoder Knob to confirm the desired value.</p>
93.2°C	9.0b	126.5°C					
Water Long Dose 15.0 s							
<table border="1" style="width: 100%;"> <tr> <td>93.2°C</td> <td>9.0b</td> <td>126.5°C</td> </tr> <tr> <td colspan="3" style="text-align: center;"> Program Water Dose </td> </tr> </table>	93.2°C	9.0b	126.5°C	Program Water Dose			<p>6 Press the Encoder Knob to start the hot water button programming.</p>
93.2°C	9.0b	126.5°C					
Program Water Dose							
<table border="1" style="width: 100%;"> <tr> <td>93.2°C</td> <td>9.0b</td> <td>126.5°C</td> </tr> <tr> <td colspan="3" style="text-align: center;"> Program Water Long Dose </td> </tr> </table>	93.2°C	9.0b	126.5°C	Program Water Long Dose			<p>7 Press the Encoder Knob to start the hot water button programming.</p>
93.2°C	9.0b	126.5°C					
Program Water Long Dose							
<table border="1" style="width: 100%;"> <tr> <td>93.2°C</td> <td>9.0b</td> <td>126.5°C</td> </tr> <tr> <td colspan="3" style="text-align: center;"> Press Water Button To Program </td> </tr> </table>	93.2°C	9.0b	126.5°C	Press Water Button To Program			<p>8 Press the hot water button to start programming the desired dose.</p>
93.2°C	9.0b	126.5°C					
Press Water Button To Program							

“Barista” Programming

Water Dose

93.2°C	9.0b	126.5°C
Water Dose Settings		

- This parameter allows the operator to program the amount of water (brewing amount) for the hot water button.

Display	Operating Procedure						
<table border="1"> <tr> <td>93.2°C</td> <td>9.0b</td> <td>126.5°C</td> </tr> <tr> <td colspan="3" style="text-align: center;"> Press Water Button To Stop </td> </tr> </table>	93.2°C	9.0b	126.5°C	Press Water Button To Stop			<p>8 Once the desired dose has been reached, press the hot water button again to stop the programming. Now the brewing time is saved.</p> <p>9 Press the the Encoder Knob to return to the “Barista” programming.</p>
93.2°C	9.0b	126.5°C					
Press Water Button To Stop							
<table border="1"> <tr> <td>93.2°C</td> <td>9.0b</td> <td>126.5°C</td> </tr> <tr> <td colspan="3" style="text-align: center;"> Water Dose Saving </td> </tr> </table>	93.2°C	9.0b	126.5°C	Water Dose Saving			
93.2°C	9.0b	126.5°C					
Water Dose Saving							
<table border="1"> <tr> <td>93.2°C</td> <td>9.0b</td> <td>126.5°C</td> </tr> <tr> <td colspan="3" style="text-align: center;"> Water Dose Exit </td> </tr> </table>	93.2°C	9.0b	126.5°C	Water Dose Exit			
93.2°C	9.0b	126.5°C					
Water Dose Exit							

Steam Flush

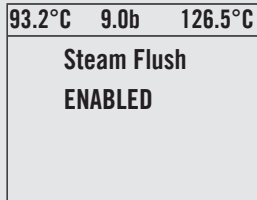

- This parameter allows the operator to enable or disable the Steam Flush function.
- If the Steam Flush function is enabled in the menu, steam will be delivered by the group with a delay of 2 seconds form portafilter removal.

Display	Operating Procedure
<p>93.2°C 9.0b 126.5°C</p> <ul style="list-style-type: none">Brew CoffeBackflush GroupPower OptionsMachine SettingsManage Profiles	<p>1 When the espresso machine is turned on, rotate the Encoder Knob until the following display appears.</p>
<p>93.2°C 9.0b 126.5°C</p> <p>Steam Flush ENABLED</p>	<p>2 Press the Encoder Knob to access the menu, rotate the Encoder Knob to choose between ENABLED and DISABLED, press the Encoder Knob to confirm the option.</p>
<p>93.2°C 9.0b 126.5°C</p> <p>Exit Menu</p>	<p>3 You must scroll to the exit menu to exit the programming mode, or press the Encoder Knob for 2 seconds.</p>



WARNING



**THE COFFEE BOILER CONTAINS WATER AT ELEVATED TEMPERATURES.
WATER TEMPERATURE OVER 52°C CAN CAUSE SEVERE BURNS INSTANTLY OR DEATH FROM SCALDING.**

“Barista” Programming (only on version with Straight-in)

Flush

93.2°C	9.0b	126.5°C
Flush ENABLED		

- This parameter allows the operator to enable or disable the Flush function.
- If the Flush function is enabled in the menu, hot water will be delivered by the group with a delay of 2 seconds form portafilter removal.

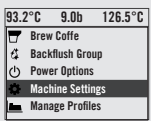
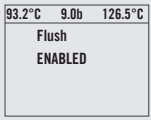
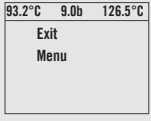
Display	Operating Procedure
 <p>93.2°C 9.0b 126.5°C</p> <ul style="list-style-type: none">Brew CoffeBackflush GroupPower OptionsMachine SettingsManage Profiles	<ol style="list-style-type: none">1 When the espresso machine is turned on, rotate the Encoder Knob until the following display appears.2 Press the Encoder Knob to access the menu, rotate the Encoder Knob to choose between ENABLED and DISABLED, press the Encoder Knob to confirm the option.3 You must scroll to the exit menu to exit the programming mode, or press the Encoder Knob for 2 seconds.
 <p>93.2°C 9.0b 126.5°C</p> <p>Flush ENABLED</p>	
 <p>93.2°C 9.0b 126.5°C</p> <p>Exit Menu</p>	



WARNING



THE STEAM HAS ELEVATED TEMPERATURES.
WATER TEMPERATURE OVER 52°C CAN CAUSE SEVERE BURNS INSTANTLY OR DEATH FROM SCALDING.

Rinse

93.2°C	9.0b	126.5°C
Rinse ENABLED		

- This parameter allows the operator to adjust the hot water supply time for washing the group.
- The rinse function is activated by operating the lever shown in figure 1 page 8 (item 14), turning it from the

dispensing position to the deactivation position within 1 second. The machine will dispense hot water for a certain number of seconds (the default setting is 4 seconds, but this can be changed to access the programming menu).

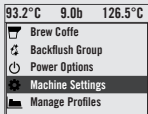
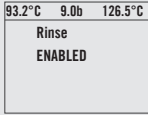
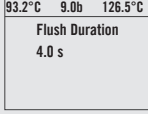
Display	Operating Procedure
	1 When the espresso machine is turned on, rotate the Encoder Knob until the following display appears.
	2 Press the Encoder Knob to access the menu, rotate the Encoder Knob to choose between ENABLED and DISABLED , press the Encoder Knob to confirm the option.
	3 Press the Encoder Knob to access the menu, rotate the Encoder Knob to modify the value, press the Encoder Knob to confirm the desired value.

WARNING

THE COFFEE BOILER CONTAINS WATER AT ELEVATED TEMPERATURES.
WATER TEMPERATURE OVER 52°C CAN CAUSE SEVERE BURNS INSTANTLY OR DEATH FROM SCALDING.

“Barista” Programming

Coffee Boiler

93.2°C	9.0b	126.5°C
Coffee Boiler Settings		

- This parameter allows the operator to enable/disable the coffee boilers.
- This parameter allows the operator to program the coffee boiler temperature.
- For an espresso machine with of multiple boilers, you can set the temperature for each group.

Display	Operating Procedure						
<table border="1"> <tr> <td>93.2°C</td> <td>9.0b</td> <td>126.5°C</td> </tr> <tr> <td colspan="3"> <ul style="list-style-type: none"> ☑ Brew Coffe ⚙ Backflush Group ⚙ Power Options ★ Machine Settings ☑ Manage Profiles </td> </tr> </table>	93.2°C	9.0b	126.5°C	<ul style="list-style-type: none"> ☑ Brew Coffe ⚙ Backflush Group ⚙ Power Options ★ Machine Settings ☑ Manage Profiles 			<ol style="list-style-type: none"> 1 When the espresso machine is turned on, rotate the Encoder Knob until the following display appears. 2 Press the Encoder Knob to access the menu. 3 Press the Encoder Knob to access the menu, rotate the Encoder Knob to choose between ENABLED and DISABLED, press the Encoder Knob to confirm the option. 4 Press the Encoder Knob to access the menu, rotate the Encoder Knob to modify the value, press the Encoder Knob to confirm the desired value.
93.2°C	9.0b	126.5°C					
<ul style="list-style-type: none"> ☑ Brew Coffe ⚙ Backflush Group ⚙ Power Options ★ Machine Settings ☑ Manage Profiles 							
<table border="1"> <tr> <td>93.2°C</td> <td>9.0b</td> <td>126.5°C</td> </tr> <tr> <td colspan="3" style="text-align: center;"> Coffee Boiler Settings </td> </tr> </table>	93.2°C	9.0b	126.5°C	Coffee Boiler Settings			
93.2°C	9.0b	126.5°C					
Coffee Boiler Settings							
<table border="1"> <tr> <td>93.2°C</td> <td>9.0b</td> <td>126.5°C</td> </tr> <tr> <td colspan="3" style="text-align: center;"> Coffee Boiler 1 ENABLED </td> </tr> </table>	93.2°C	9.0b	126.5°C	Coffee Boiler 1 ENABLED			
93.2°C	9.0b	126.5°C					
Coffee Boiler 1 ENABLED							
<table border="1"> <tr> <td>93.2°C</td> <td>9.0b</td> <td>126.5°C</td> </tr> <tr> <td colspan="3"> CB1 Temperature Current:94.5 Target:94.5 </td> </tr> </table>	93.2°C	9.0b	126.5°C	CB1 Temperature Current:94.5 Target:94.5			
93.2°C	9.0b	126.5°C					
CB1 Temperature Current:94.5 Target:94.5							

Coffee Boiler

93.2°C	9.0b	126.5°C
Coffee Boiler Settings		

- This parameter allows the operator to enable/disable the coffee boilers.
- This parameter allows the operator to program the coffee boiler temperature.
- For an espresso machine with of multiple boilers, you can set the temperature for each group.



Display	Operating Procedure												
<table border="1" style="width: 100%;"> <tr> <td>93.2°C</td> <td>9.0b</td> <td>126.5°C</td> </tr> <tr> <td colspan="3" style="text-align: center;"> Coffee Boiler Exit </td> </tr> </table> <table border="1" style="width: 100%;"> <tr> <td>93.2°C</td> <td>9.0b</td> <td>126.5°C</td> </tr> <tr> <td colspan="3" style="text-align: center;"> Exit Menu </td> </tr> </table>	93.2°C	9.0b	126.5°C	Coffee Boiler Exit			93.2°C	9.0b	126.5°C	Exit Menu			<p>5 Press the Encoder Knob to quit the submenu.</p> <p>6 You must scroll to the exit menu to exit the programming mode, or press the Encoder Knob for 2 seconds.</p>
93.2°C	9.0b	126.5°C											
Coffee Boiler Exit													
93.2°C	9.0b	126.5°C											
Exit Menu													

“Barista” Programming

Cup Warmer

93.2°C	9.0b	126.5°C
Cup Warmer ENABLED		

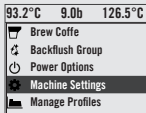
- This parameter allows the operator to enable or disable the cups heating function.
- This function is displayed only on the models of espresso machine equipped with this accessory.

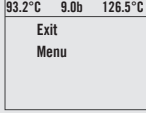
Display	Operating Procedure
 <p>93.2°C 9.0b 126.5°C</p> <ul style="list-style-type: none"> ☑ Brew Coffe ⚙ Backflush Group ⏻ Power Options ★ Machine Settings 📄 Manage Profiles 	<ol style="list-style-type: none"> 1 When the espresso machine is turned on, rotate the Encoder Knob until the following display appears. 2 Press the Encoder Knob to access the menu, rotate the Encoder Knob to choose between ENABLED and DISABLED, press the Encoder Knob to confirm the option. 3 You must scroll to the exit menu to exit the programming mode, or press the Encoder Knob for 2 seconds.
 <p>93.2°C 9.0b 126.5°C</p> <p style="text-align: center;">Cup Warmer ENABLED</p>	
 <p>93.2°C 9.0b 126.5°C</p> <p style="text-align: center;">Exit Menu</p>	

Display Brightness

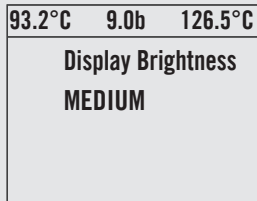

- This parameter allows the operator to adjust the brightness of the screen.

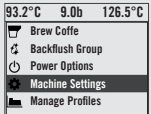
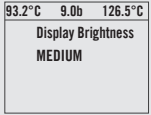
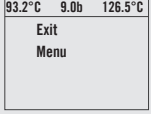
Display	Operating Procedure
  	<ol style="list-style-type: none"> 1 When the espresso machine is turned on, rotate the Encoder Knob until the following display appears. 2 Press the Encoder Knob to access the menu, rotate the Encoder Knob to choose between LOW, MEDIUM and HIGH, press the Encoder Knob to confirm the option. 3 You must scroll to the exit menu to exit the programming mode, or press the Encoder Knob for 2 seconds.

“Barista” Programming

Reset Profiles

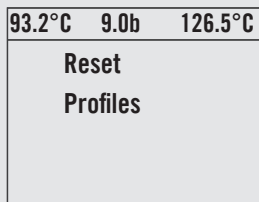

- This parameter allows the operator to reset the pressure guide profiles to the original factory settings.

Display	Operating Procedure
<p>The screenshot shows a digital display with three temperature readings at the top: 93.2°C, 9.0b, and 126.5°C. Below these readings, a menu is displayed with the following options: Brew Coffe, Backflush Group, Power Options, Machine Settings (highlighted), and Manage Profiles.</p>	1 When the espresso machine is turned on, rotate the Encoder Knob until the following display appears.
<p>The screenshot shows a digital display with three temperature readings at the top: 93.2°C, 9.0b, and 126.5°C. Below these readings, the text 'Reset Profiles' is centered on the screen.</p>	2 Press the Encoder Knob to access the menu.
<p>The screenshot shows a digital display with three temperature readings at the top: 93.2°C, 9.0b, and 126.5°C. Below these readings, the text 'Do you want to Reset Profiles?' is centered on the screen.</p>	3 Press the Encoder Knob to reset the settings.
<p>The screenshot shows a digital display with three temperature readings at the top: 93.2°C, 9.0b, and 126.5°C. Below these readings, the text 'Cancelling... ResettingProfiles...' is centered on the screen.</p>	4 Reset in progress.

Water Quality

93.2°C	9.0b	126.5°C
Water Sensor		
Total Hardness:20 ppm		
TDS:140 ppm		

- This parameter allows the operator to view the TDS and water hardness values that are measured by the water probe at the inlet of the coffee machine.

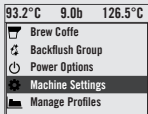
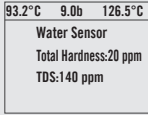
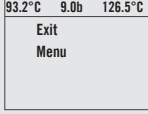

Display	Operating Procedure
 <p>93.2°C 9.0b 126.5°C</p> <ul style="list-style-type: none"> Brew Coffe Backflush Group Power Options Machine Settings Manage Profiles 	<ol style="list-style-type: none"> 1 When the espresso machine is turned on, rotate the Encoder Knob until the following display appears. 2 Display of water hardness and TDS values. 3 You must scroll to the exit menu to exit the programming mode, or press the Encoder Knob for 2 seconds.
 <p>93.2°C 9.0b 126.5°C</p> <p>Water Sensor</p> <p>Total Hardness:20 ppm</p> <p>TDS:140 ppm</p>	
 <p>93.2°C 9.0b 126.5°C</p> <p>Exit</p> <p>Menu</p>	

“Barista” Programming

Gateway

93.2°C	9.0b	126.5°C
Configure Gateway		

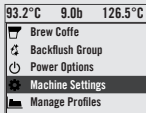
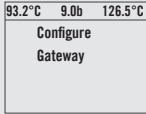
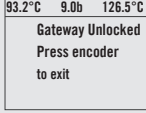
- This parameter allows the operator to connect the coffee machine to the WiFi connection.

Display	Operating Procedure
	1 When the espresso machine is turned on, rotate the Encoder Knob until the following display appears.
	2 Press the Encoder Knob to access the menu.
	3 The Gateway is ready to connect to the WiFi network. 3 Press the Encoder Knob to quit the submenu.
	4 You must scroll to the exit menu to exit the programming mode, or press the Encoder Knob for 2 seconds.

Exit Menu

93.2°C	9.0b	126.5°C
Exit Menu		

- This parameter allows the technician to exit the “Barista” programming and return to the normal use of the espresso machine.

Display	Operating Procedure						
<table border="1"> <tr> <td>93.2°C</td> <td>9.0b</td> <td>126.5°C</td> </tr> <tr> <td colspan="3" style="text-align: center;">Exit Menu</td> </tr> </table>	93.2°C	9.0b	126.5°C	Exit Menu			<ol style="list-style-type: none"> 1 Press the Encoder Knob to exit the programming mode and return to the normal use of the espresso machine.
93.2°C	9.0b	126.5°C					
Exit Menu							

“Technical” Programming

Language

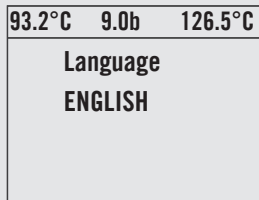

- This parameter allows the technician to change the language of the display.

Display	Operating Procedure
	<p>1 When the espresso machine is on, rotate the Encoder Knob until the following is displayed.</p>
	<p>2 Press the Encoder Knob until it the following is displayed.</p>
	<p>3 Press and hold the Encoder Knob. After about 5 seconds the following screen is displayed.</p>
	<p>4 After entering the password and accessing the “Technician” programming menu, rotate the Encoder Knob until the following is displayed.</p>

Language

93.2°C	9.0b	126.5°C
Language		
ENGLISH		

- This parameter allows the technician to change the language of the display.

Display	Operating Procedure									
<table border="1"> <tr> <td>93.2°C</td> <td>9.0b</td> <td>126.5°C</td> </tr> <tr> <td colspan="3">Language</td> </tr> <tr> <td colspan="3">ENGLISH</td> </tr> </table>	93.2°C	9.0b	126.5°C	Language			ENGLISH			<p>5 Press the Encoder Knob to access the parameter, rotate the Encoder Knob to choose the desired language, press the Encoder Knob to confirm your choice.</p>
93.2°C	9.0b	126.5°C								
Language										
ENGLISH										
<table border="1"> <tr> <td>93.2°C</td> <td>9.0b</td> <td>126.5°C</td> </tr> <tr> <td colspan="3">Exit</td> </tr> <tr> <td colspan="3">Menu</td> </tr> </table>	93.2°C	9.0b	126.5°C	Exit			Menu			<p>6 You must scroll to the exit menu to exit the programming mode, or press the Encoder Knob for 2 seconds.</p>
93.2°C	9.0b	126.5°C								
Exit										
Menu										

“Technical” Programming

Temperature Measurement Units

93.2°C	9.0b	126.5°C
Temp Units		
CELSIUS		

Press the Encoder Knob to access the parameter, rotate the Encoder Knob to choose the desired language, press the Encoder Knob to confirm your choice.

Display	Operating Procedure									
<table border="1"><tr><td>93.2°C</td><td>9.0b</td><td>126.5°C</td></tr><tr><td colspan="3">Password</td></tr><tr><td colspan="3">0000</td></tr></table>	93.2°C	9.0b	126.5°C	Password			0000			<ol style="list-style-type: none">1 After entering the password and accessing the “Technician” programming menu, rotate the Encoder Knob until the following is displayed.2 Press the Encoder Knob to access the menu, rotate the Encoder Knob to choose between CELSIUS and FAHRENHEIT, Press the Encoder Knob to confirm the option.3 You must scroll to the exit menu to exit the programming mode, or press the Encoder Knob for 2 seconds.
93.2°C	9.0b	126.5°C								
Password										
0000										
<table border="1"><tr><td>93.2°C</td><td>9.0b</td><td>126.5°C</td></tr><tr><td colspan="3">Temp Units</td></tr><tr><td colspan="3">CELSIUS</td></tr></table>	93.2°C	9.0b	126.5°C	Temp Units			CELSIUS			
93.2°C	9.0b	126.5°C								
Temp Units										
CELSIUS										
<table border="1"><tr><td>93.2°C</td><td>9.0b</td><td>126.5°C</td></tr><tr><td colspan="3">Exit</td></tr><tr><td colspan="3">Menu</td></tr></table>	93.2°C	9.0b	126.5°C	Exit			Menu			
93.2°C	9.0b	126.5°C								
Exit										
Menu										

Name

93.2°C	9.0b	126.5°C
Name LaMarzocco		

- This parameter allows the technician to program a 16 character user name.
- The user name is displayed continuously on the display on the second line.

Display	Operating Procedure						
<table border="1" style="width: 100%;"> <tr> <td>93.2°C</td> <td>9.0b</td> <td>126.5°C</td> </tr> <tr> <td colspan="3" style="text-align: center;"> Password 0000 </td> </tr> </table>	93.2°C	9.0b	126.5°C	Password 0000			<ol style="list-style-type: none"> 1 After entering the password and accessing the “Technician” programming menu, rotate the Encoder Knob until the following is displayed. 2 Press the Encoder Knob to access the menu, rotate the Encoder Knob to choose the desired letter, press the Encoder Knob to confirm your choice, then proceed with the writing operations. 3 You must scroll to the exit menu to exit the programming mode, or press the Encoder Knob for 2 seconds.
93.2°C	9.0b	126.5°C					
Password 0000							
<table border="1" style="width: 100%;"> <tr> <td>93.2°C</td> <td>9.0b</td> <td>126.5°C</td> </tr> <tr> <td colspan="3" style="text-align: center;"> Name LaMarzocco </td> </tr> </table>	93.2°C	9.0b	126.5°C	Name LaMarzocco			
93.2°C	9.0b	126.5°C					
Name LaMarzocco							
<table border="1" style="width: 100%;"> <tr> <td>93.2°C</td> <td>9.0b</td> <td>126.5°C</td> </tr> <tr> <td colspan="3" style="text-align: center;"> Exit Menu </td> </tr> </table>	93.2°C	9.0b	126.5°C	Exit Menu			
93.2°C	9.0b	126.5°C					
Exit Menu							

“Technical” Programming

Potentiometer Calibrate

93.2°C	9.0b	126.5°C
Calibrate Pots. Settings		

- This parameter allows the technician to calibrate the potentiometer, adjusting the steam and coffee delivery starting and end point.

Display	Operating Procedure						
<table border="1"> <tr> <td>93.2°C</td> <td>9.0b</td> <td>126.5°C</td> </tr> <tr> <td colspan="3" style="text-align: center;"> Password 0000 </td> </tr> </table>	93.2°C	9.0b	126.5°C	Password 0000			<ol style="list-style-type: none"> 1 After entering the password and accessing the “Technician” programming menu, rotate the Encoder Knob until the following is displayed. 2 Press the Encoder Knob to access the menu. 3 Press the Encoder Knob to start calibrating the potentiometer of the first Coffee Boiler. 4 Operate the brewing lever bringing it to the left position, then press the Encoder Knob.
93.2°C	9.0b	126.5°C					
Password 0000							
<table border="1"> <tr> <td>93.2°C</td> <td>9.0b</td> <td>126.5°C</td> </tr> <tr> <td colspan="3" style="text-align: center;"> Calibrate Pots Settings </td> </tr> </table>	93.2°C	9.0b	126.5°C	Calibrate Pots Settings			
93.2°C	9.0b	126.5°C					
Calibrate Pots Settings							
<table border="1"> <tr> <td>93.2°C</td> <td>9.0b</td> <td>126.5°C</td> </tr> <tr> <td colspan="3" style="text-align: center;"> Calibrazione G1 Pot </td> </tr> </table>	93.2°C	9.0b	126.5°C	Calibrazione G1 Pot			
93.2°C	9.0b	126.5°C					
Calibrazione G1 Pot							
<table border="1"> <tr> <td>93.2°C</td> <td>9.0b</td> <td>126.5°C</td> </tr> <tr> <td colspan="3" style="text-align: center;"> Ruotare G1 Pot a SX e Premere Enter </td> </tr> </table>	93.2°C	9.0b	126.5°C	Ruotare G1 Pot a SX e Premere Enter			
93.2°C	9.0b	126.5°C					
Ruotare G1 Pot a SX e Premere Enter							

Potentiometer Calibrate

93.2°C	9.0b	126.5°C
Calibrate Pots. Settings		

- This parameter allows the technician to calibrate the potentiometer, adjusting the steam and coffee delivery starting and end point.

Display	Operating Procedure						
<table border="1"> <tr> <td>93.2°C</td> <td>9.0b</td> <td>126.5°C</td> </tr> <tr> <td colspan="3" style="text-align: center;"> Ruotare G1 Pot a DX e Premere Enter </td> </tr> </table>	93.2°C	9.0b	126.5°C	Ruotare G1 Pot a DX e Premere Enter			<p>5 Operate the brewing lever bringing it to the right position, then press the Encoder Knob.</p>
93.2°C	9.0b	126.5°C					
Ruotare G1 Pot a DX e Premere Enter							
<table border="1"> <tr> <td>93.2°C</td> <td>9.0b</td> <td>126.5°C</td> </tr> <tr> <td colspan="3" style="text-align: center;"> Calibrazione Vapore SX </td> </tr> </table>	93.2°C	9.0b	126.5°C	Calibrazione Vapore SX			<p>6 Premere la Manopola Encoder per avviare la calibrazione del potenziometro della lancia vapore di sinistra.</p>
93.2°C	9.0b	126.5°C					
Calibrazione Vapore SX							
<table border="1"> <tr> <td>93.2°C</td> <td>9.0b</td> <td>126.5°C</td> </tr> <tr> <td colspan="3" style="text-align: center;"> Abbassare Leva SX e Premere Enter </td> </tr> </table>	93.2°C	9.0b	126.5°C	Abbassare Leva SX e Premere Enter			<p>7 Press the Encoder Knob to start calibrating the potentiometer of the left-hand steam wand.</p>
93.2°C	9.0b	126.5°C					
Abbassare Leva SX e Premere Enter							
<table border="1"> <tr> <td>93.2°C</td> <td>9.0b</td> <td>126.5°C</td> </tr> <tr> <td colspan="3" style="text-align: center;"> Alzare Leva SX e Premere Enter </td> </tr> </table>	93.2°C	9.0b	126.5°C	Alzare Leva SX e Premere Enter			<p>8 Operate the left-hand steam lever, fully lowering it, then press the Encoder Knob.</p>
93.2°C	9.0b	126.5°C					
Alzare Leva SX e Premere Enter							

“Technical” Programming

Potentiometer Calibrate

93.2°C	9.0b	126.5°C
Calibrate Pots. Settings		

- This parameter allows the technician to calibrate the potentiometer, adjusting the steam and coffee delivery starting and end point.

Display	Operating Procedure						
<table border="1"><tr><td>93.2°C</td><td>9.0b</td><td>126.5°C</td></tr><tr><td colspan="3">Calibrazione Vapore DX</td></tr></table>	93.2°C	9.0b	126.5°C	Calibrazione Vapore DX			9 Press the Encoder Knob to start calibrating the potentiometer of the right-hand steam wand.
93.2°C	9.0b	126.5°C					
Calibrazione Vapore DX							
<table border="1"><tr><td>93.2°C</td><td>9.0b</td><td>126.5°C</td></tr><tr><td colspan="3">Abbassare Leva DX e Premere Enter</td></tr></table>	93.2°C	9.0b	126.5°C	Abbassare Leva DX e Premere Enter			10 Operate the right-hand steam lever, fully lowering it, then press the Encoder Knob.
93.2°C	9.0b	126.5°C					
Abbassare Leva DX e Premere Enter							
<table border="1"><tr><td>93.2°C</td><td>9.0b</td><td>126.5°C</td></tr><tr><td colspan="3">Alzare Leva DX e Premere Enter</td></tr></table>	93.2°C	9.0b	126.5°C	Alzare Leva DX e Premere Enter			11 Operate the right-hand steam lever, fully raising it, then press the Encoder Knob.
93.2°C	9.0b	126.5°C					
Alzare Leva DX e Premere Enter							
<table border="1"><tr><td>93.2°C</td><td>9.0b</td><td>126.5°C</td></tr><tr><td colspan="3">Calibrate Pots Exit</td></tr></table>	93.2°C	9.0b	126.5°C	Calibrate Pots Exit			12 Press the Encoder Knob to quit the submenu.
93.2°C	9.0b	126.5°C					
Calibrate Pots Exit							

AV Brewing

93.2°C	9.0b	126.5°C
AV Brewing Settings		

- This parameter allows the operator to program the amount of coffee (brewing amount) for each Selection Indicator.
- The brewing amount can be set in terms of time (sec.), pulses, mass or brewratio.
- Once programmed, the Selection Indicator remains lighted.
- It is possible to set the dose for both a short and a long shot on the same Selection Indicator.
- PULSE mode: control of doses in volume
- MASS mode: control of doses in mass
- BREW RATIO mode: ratio between the coffee powder and the weight of the drink

Display	Operating Procedure						
<table border="1"> <tr> <td>93.2°C</td> <td>9.0b</td> <td>126.5°C</td> </tr> <tr> <td colspan="3" style="text-align: center;">Password 0000</td> </tr> </table>	93.2°C	9.0b	126.5°C	Password 0000			<ol style="list-style-type: none"> 1 After entering the password and accessing the “Technician” programming menu, rotate the Encoder Knob until the following is displayed. 2 Press the Encoder Knob to access the menu. 3 Press the Encoder Knob to access the menu. 4 Press the Encoder Knob to access the menu, rotate the Encoder Knob to modify the value, press the Encoder Knob to confirm the desired value.
93.2°C	9.0b	126.5°C					
Password 0000							
<table border="1"> <tr> <td>93.2°C</td> <td>9.0b</td> <td>126.5°C</td> </tr> <tr> <td colspan="3" style="text-align: center;">AV Brewing Settings</td> </tr> </table>	93.2°C	9.0b	126.5°C	AV Brewing Settings			
93.2°C	9.0b	126.5°C					
AV Brewing Settings							
<table border="1"> <tr> <td>93.2°C</td> <td>9.0b</td> <td>126.5°C</td> </tr> <tr> <td colspan="3" style="text-align: center;">G1 AV Mode Settings</td> </tr> </table>	93.2°C	9.0b	126.5°C	G1 AV Mode Settings			
93.2°C	9.0b	126.5°C					
G1 AV Mode Settings							
<table border="1"> <tr> <td>93.2°C</td> <td>9.0b</td> <td>126.5°C</td> </tr> <tr> <td colspan="3" style="text-align: center;">G1 Pressure 9.0b</td> </tr> </table>	93.2°C	9.0b	126.5°C	G1 Pressure 9.0b			
93.2°C	9.0b	126.5°C					
G1 Pressure 9.0b							

“Technical” Programming

AV Brewing

93.2°C	9.0b	126.5°C
AV Brewing Settings		

- This parameter allows the operator to program the amount of coffee (brewing amount) for each Selection Indicator.
- The brewing amount can be set in terms of time (sec.), pulses, mass or brewratio.
- Once programmed, the Selection Indicator remains lighted.
- It is possible to set the dose for both a short and a long shot on the same Selection Indicator.
- PULSE mode: control of doses in volume
- MASS mode: control of doses in mass
- BREW RATIO mode: ratio between the coffee powder and the weight of the drink

Display	Operating Procedure						
<table border="1"> <tr> <td>93.2°C</td> <td>9.0b</td> <td>126.5°C</td> </tr> <tr> <td colspan="3" style="text-align: center;"> G1 Mode MASSA </td> </tr> </table>	93.2°C	9.0b	126.5°C	G1 Mode MASSA			<p>5 Press the Encoder Knob to access the menu, rotate the Encoder Knob to choose between PULSES, MASS and BREW RATIO, press the Encoder Knob to confirm the option.</p> <p>6 Press the Encoder Knob to access the menu, rotate the Encoder Knob to modify the value, press the Encoder Knob to confirm the desired value.</p> <p>7 Press the Encoder Knob to quit the submenu.</p> <p>8 Press the the Encoder Knob to return to the “Technician” programming.</p>
93.2°C	9.0b	126.5°C					
G1 Mode MASSA							
<table border="1"> <tr> <td>93.2°C</td> <td>9.0b</td> <td>126.5°C</td> </tr> <tr> <td colspan="3" style="text-align: center;"> G1 Dose 50.0g </td> </tr> </table>	93.2°C	9.0b	126.5°C	G1 Dose 50.0g			
93.2°C	9.0b	126.5°C					
G1 Dose 50.0g							
<table border="1"> <tr> <td>93.2°C</td> <td>9.0b</td> <td>126.5°C</td> </tr> <tr> <td colspan="3" style="text-align: center;"> G1 AV Mode Exit </td> </tr> </table>	93.2°C	9.0b	126.5°C	G1 AV Mode Exit			
93.2°C	9.0b	126.5°C					
G1 AV Mode Exit							
<table border="1"> <tr> <td>93.2°C</td> <td>9.0b</td> <td>126.5°C</td> </tr> <tr> <td colspan="3" style="text-align: center;"> AV Brewing Exit </td> </tr> </table>	93.2°C	9.0b	126.5°C	AV Brewing Exit			
93.2°C	9.0b	126.5°C					
AV Brewing Exit							

Water Dose

93.2°C	9.0b	126.5°C
Water Dose Settings		

- This parameter allows the operator to program the amount of water (brewing amount) for the hot water button.

Display	Operating Procedure						
<table border="1"> <tr> <td>93.2°C</td> <td>9.0b</td> <td>126.5°C</td> </tr> <tr> <td colspan="3"> Password 0000 </td> </tr> </table>	93.2°C	9.0b	126.5°C	Password 0000			<ol style="list-style-type: none"> 1 After entering the password and accessing the “Technician” programming menu, rotate the Encoder Knob until the following is displayed. 2 Press the Encoder Knob to access the menu. 3 Press the Encoder Knob to access the menu, rotate the Encoder Knob to choose between WITH PUMP and WITHOUT PUMP, press the Encoder Knob to confirm the option. 3 Press the Encoder Knob to access the menu, rotate the Encoder Knob to choose between CONTINUOUS or TIME, Press the Encoder Knob to confirm the option.
93.2°C	9.0b	126.5°C					
Password 0000							
<table border="1"> <tr> <td>93.2°C</td> <td>9.0b</td> <td>126.5°C</td> </tr> <tr> <td colspan="3"> Water Dose Settings </td> </tr> </table>	93.2°C	9.0b	126.5°C	Water Dose Settings			
93.2°C	9.0b	126.5°C					
Water Dose Settings							
<table border="1"> <tr> <td>93.2°C</td> <td>9.0b</td> <td>126.5°C</td> </tr> <tr> <td colspan="3"> Water Dose WITHOUT PUMP </td> </tr> </table>	93.2°C	9.0b	126.5°C	Water Dose WITHOUT PUMP			
93.2°C	9.0b	126.5°C					
Water Dose WITHOUT PUMP							
<table border="1"> <tr> <td>93.2°C</td> <td>9.0b</td> <td>126.5°C</td> </tr> <tr> <td colspan="3"> Water Dose CONTINUOUS </td> </tr> </table>	93.2°C	9.0b	126.5°C	Water Dose CONTINUOUS			
93.2°C	9.0b	126.5°C					
Water Dose CONTINUOUS							

“Technical” Programming

Water Dose

93.2°C	9.0b	126.5°C
Water Dose Settings		

- This parameter allows the operator to program the amount of water (brewing amount) for the hot water button.

Display	Operating Procedure						
<table border="1"> <tr> <td>93.2°C</td> <td>9.0b</td> <td>126.5°C</td> </tr> <tr> <td colspan="3" style="text-align: center;"> Water Dose 15.0 s </td> </tr> </table>	93.2°C	9.0b	126.5°C	Water Dose 15.0 s			<p>5 Press the Encoder Knob to access the menu, rotate the Encoder Knob to modify the value, press the Encoder Knob to confirm the desired value.</p>
93.2°C	9.0b	126.5°C					
Water Dose 15.0 s							
<table border="1"> <tr> <td>93.2°C</td> <td>9.0b</td> <td>126.5°C</td> </tr> <tr> <td colspan="3" style="text-align: center;"> Water Long Dose 15.0 s </td> </tr> </table>	93.2°C	9.0b	126.5°C	Water Long Dose 15.0 s			<p>6 Press the Encoder Knob to access the menu, rotate the Encoder Knob to modify the value, press the Encoder Knob to confirm the desired value.</p>
93.2°C	9.0b	126.5°C					
Water Long Dose 15.0 s							
<table border="1"> <tr> <td>93.2°C</td> <td>9.0b</td> <td>126.5°C</td> </tr> <tr> <td colspan="3" style="text-align: center;"> Program Water Dose </td> </tr> </table>	93.2°C	9.0b	126.5°C	Program Water Dose			<p>7 Press the Encoder Knob to start the hot water button programming.</p>
93.2°C	9.0b	126.5°C					
Program Water Dose							
<table border="1"> <tr> <td>93.2°C</td> <td>9.0b</td> <td>126.5°C</td> </tr> <tr> <td colspan="3" style="text-align: center;"> Program Water Long Dose </td> </tr> </table>	93.2°C	9.0b	126.5°C	Program Water Long Dose			<p>8 Press the Encoder Knob to start the hot water button programming.</p>
93.2°C	9.0b	126.5°C					
Program Water Long Dose							

“Technical” Programming (only on version with Straight-in)

Steam Flush

93.2°C	9.0b	126.5°C
Steam Flush ENABLED		

- This parameter allows the operator to enable or disable the Steam Flush function.
- If the Steam Flush function is enabled in the menu, steam will be delivered by the group with a delay of 2 seconds form portafilter removal.

Display	Operating Procedure						
<table border="1"> <tr> <td>93.2°C</td> <td>9.0b</td> <td>126.5°C</td> </tr> <tr> <td colspan="3" style="text-align: center;"> Password 0000 </td> </tr> </table>	93.2°C	9.0b	126.5°C	Password 0000			<ol style="list-style-type: none"> 1 After entering the password and accessing the “Technician” programming menu, rotate the Encoder Knob until the following is displayed. 2 Press the Encoder Knob to access the menu, rotate the Encoder Knob to choose between ENABLED and DISABLED, press the Encoder Knob to confirm the option. 3 You must scroll to the exit menu to exit the programming mode, or press the Encoder Knob for 2 seconds.
93.2°C	9.0b	126.5°C					
Password 0000							
<table border="1"> <tr> <td>93.2°C</td> <td>9.0b</td> <td>126.5°C</td> </tr> <tr> <td colspan="3" style="text-align: center;"> Steam Flush ENABLED </td> </tr> </table>	93.2°C	9.0b	126.5°C	Steam Flush ENABLED			
93.2°C	9.0b	126.5°C					
Steam Flush ENABLED							
<table border="1"> <tr> <td>93.2°C</td> <td>9.0b</td> <td>126.5°C</td> </tr> <tr> <td colspan="3" style="text-align: center;"> Exit Menu </td> </tr> </table>	93.2°C	9.0b	126.5°C	Exit Menu			
93.2°C	9.0b	126.5°C					
Exit Menu							



WARNING



**THE STEAM HAS ELEVATED TEMPERATURES.
 WATER TEMPERATURE OVER 52°C CAN CAUSE SEVERE BURNS INSTANTLY OR DEATH FROM SCALDING.**

Flush

93.2°C	9.0b	126.5°C
Flush ENABLED		

- This parameter allows the operator to enable or disable the Steam Flush function.
- If the Steam Flush function is enabled in the menu, steam will be delivered by the group with a delay of 2 seconds form portafilter removal.

Display	Operating Procedure						
<table border="1"><tr><td>93.2°C</td><td>9.0b</td><td>126.5°C</td></tr><tr><td colspan="3">Password 0000</td></tr></table>	93.2°C	9.0b	126.5°C	Password 0000			<ol style="list-style-type: none">1 After entering the password and accessing the “Technician” programming menu, rotate the Encoder Knob until the following is displayed.2 Press the Encoder Knob to access the menu, rotate the Encoder Knob to choose between ENABLED and DISABLED, press the Encoder Knob to confirm the option.3 You must scroll to the exit menu to exit the programming mode, or press the Encoder Knob for 2 seconds.
93.2°C	9.0b	126.5°C					
Password 0000							
<table border="1"><tr><td>93.2°C</td><td>9.0b</td><td>126.5°C</td></tr><tr><td colspan="3">Flush ENABLED</td></tr></table>	93.2°C	9.0b	126.5°C	Flush ENABLED			
93.2°C	9.0b	126.5°C					
Flush ENABLED							
<table border="1"><tr><td>93.2°C</td><td>9.0b</td><td>126.5°C</td></tr><tr><td colspan="3">Exit Menu</td></tr></table>	93.2°C	9.0b	126.5°C	Exit Menu			
93.2°C	9.0b	126.5°C					
Exit Menu							

WARNING

THE COFFEE BOILER CONTAINS WATER AT ELEVATED TEMPERATURES.
WATER TEMPERATURE OVER 52°C CAN CAUSE SEVERE BURNS INSTANTLY OR DEATH FROM SCALDING.

“Technical” Programming (only on version without Straight-in)

Rinse

93.2°C	9.0b	126.5°C
Rinse ENABLED		

- This parameter allows the operator to adjust the hot water supply time for washing the group.
- The rinse function is activated by operating the lever shown in figure 1 page 8 (item 14), turning it from the

dispensing position to the deactivation position within 1 second. The machine will dispense hot water for a certain number of seconds (the default setting is 4 seconds, but this can be changed to access the programming menu).

Display	Operating Procedure						
<table border="1"> <tr> <td>93.2°C</td> <td>9.0b</td> <td>126.5°C</td> </tr> <tr> <td colspan="3" style="text-align: center;"> Password 0000 </td> </tr> </table>	93.2°C	9.0b	126.5°C	Password 0000			<ol style="list-style-type: none"> 1 After entering the password and accessing the “Technician” programming menu, rotate the Encoder Knob until the following is displayed. 2 Press the Encoder Knob to access the menu, rotate the Encoder Knob to choose between ENABLED and DISABLED, press the Encoder Knob to confirm the option. 3 Press the Encoder Knob to access the menu, rotate the Encoder Knob to modify the value, press the Encoder Knob to confirm the desired value.
93.2°C	9.0b	126.5°C					
Password 0000							
<table border="1"> <tr> <td>93.2°C</td> <td>9.0b</td> <td>126.5°C</td> </tr> <tr> <td colspan="3" style="text-align: center;"> Rinse ENABLED </td> </tr> </table>	93.2°C	9.0b	126.5°C	Rinse ENABLED			
93.2°C	9.0b	126.5°C					
Rinse ENABLED							
<table border="1"> <tr> <td>93.2°C</td> <td>9.0b</td> <td>126.5°C</td> </tr> <tr> <td colspan="3" style="text-align: center;"> Flush Duration 4.0 s </td> </tr> </table>	93.2°C	9.0b	126.5°C	Flush Duration 4.0 s			
93.2°C	9.0b	126.5°C					
Flush Duration 4.0 s							

WARNING

THE STEAM HAS ELEVATED TEMPERATURES.
WATER TEMPERATURE OVER 52°C CAN CAUSE SEVERE BURNS INSTANTLY OR DEATH FROM SCALDING.

Scale Settings

93.2°C	9.0b	126.5°C
Scale Settings		

- This parameter enables the technician to set some scale parameters like:
 - Enabling/disabling the offset parameter;
 - Setting the weight reading time;
 - Calibrating the scales;
 - Updating the scale software.

Display	Operating Procedure						
<table border="1"> <tr> <td>93.2°C</td> <td>9.0b</td> <td>126.5°C</td> </tr> <tr> <td colspan="3"> Password 0000 </td> </tr> </table>	93.2°C	9.0b	126.5°C	Password 0000			<ol style="list-style-type: none"> 1 After entering the password and accessing the “Technician” programming menu, rotate the Encoder Knob until the following is displayed. 2 Press the Encoder Knob to access the menu. 3 Press the Encoder Knob to access the menu, rotate the Encoder Knob to choose between ENABLED and DISABLED, press the Encoder Knob to confirm the option. 4 Press the Encoder Knob to access the menu, rotate the Encoder Knob to modify the value, press the Encoder Knob to confirm the desired value. This parameter is common to all groups.
93.2°C	9.0b	126.5°C					
Password 0000							
<table border="1"> <tr> <td>93.2°C</td> <td>9.0b</td> <td>126.5°C</td> </tr> <tr> <td colspan="3"> Scale Settings </td> </tr> </table>	93.2°C	9.0b	126.5°C	Scale Settings			
93.2°C	9.0b	126.5°C					
Scale Settings							
<table border="1"> <tr> <td>93.2°C</td> <td>9.0b</td> <td>126.5°C</td> </tr> <tr> <td colspan="3"> Auto Offset ENABLED </td> </tr> </table>	93.2°C	9.0b	126.5°C	Auto Offset ENABLED			
93.2°C	9.0b	126.5°C					
Auto Offset ENABLED							
<table border="1"> <tr> <td>93.2°C</td> <td>9.0b</td> <td>126.5°C</td> </tr> <tr> <td colspan="3"> Scale Tare T. 3s </td> </tr> </table>	93.2°C	9.0b	126.5°C	Scale Tare T. 3s			
93.2°C	9.0b	126.5°C					
Scale Tare T. 3s							

“Technical” Programming

Scale Settings

93.2°C	9.0b	126.5°C
Scale Settings		

- This parameter enables the technician to set some scale parameters like:
 - Enabling/disabling the offset parameter;
 - Setting the weight reading time;
 - Calibrating the scales;
 - Updating the scale software.

Display	Operating Procedure						
<table border="1"> <tr> <td>93.2°C</td> <td>9.0b</td> <td>126.5°C</td> </tr> <tr> <td colspan="3" style="text-align: center;">G1 Scale PRESENT</td> </tr> </table>	93.2°C	9.0b	126.5°C	G1 Scale PRESENT			<p>5 This parameter indicates that the scale is properly connected; navigate using the Encoder Knob to display the next menu.</p> <p>6 Press the Encoder Knob to start the calibration procedure.</p> <p>Remove any object from the scale, then press the Encoder Knob to confirm.</p> <p>7 Place the reference weights onto the scale, then press the Encoder Knob to confirm. At the end of the process, the self-calibration values or a confirmation message are displayed. Repeat this operation for each group.</p> <p>8 Press the Encoder Knob to enter the menu and place the reference weights onto the scale.</p>
93.2°C	9.0b	126.5°C					
G1 Scale PRESENT							
<table border="1"> <tr> <td>93.2°C</td> <td>9.0b</td> <td>126.5°C</td> </tr> <tr> <td colspan="3" style="text-align: center;">Calibrare Scale G1</td> </tr> </table>	93.2°C	9.0b	126.5°C	Calibrare Scale G1			
93.2°C	9.0b	126.5°C					
Calibrare Scale G1							
<table border="1"> <tr> <td>G1 Bilanc. Scar. e Premi Enter</td> </tr> </table>	G1 Bilanc. Scar. e Premi Enter						
G1 Bilanc. Scar. e Premi Enter							
<table border="1"> <tr> <td>Mett. 100g su G1 e Premi Enter</td> </tr> </table>	Mett. 100g su G1 e Premi Enter						
Mett. 100g su G1 e Premi Enter							
<table border="1"> <tr> <td>Start Scale Testing</td> </tr> </table>	Start Scale Testing						
Start Scale Testing							
<table border="1"> <tr> <td>0.0 0.0 0.0 Enter per Uscire</td> </tr> </table>	0.0 0.0 0.0 Enter per Uscire						
0.0 0.0 0.0 Enter per Uscire							

Scale Settings

93.2°C	9.0b	126.5°C
Scale Settings		

- This parameter enables the technician to set some scale parameters like:
 - Enabling/disabling the offset parameter;
 - Setting the weight reading time;
 - Calibrating the scales;
 - Updating the scale software.

Display	Operating Procedure						
<table border="1"> <tr> <td>93.2°C</td> <td>9.0b</td> <td>126.5°C</td> </tr> <tr> <td colspan="3" style="text-align: center;"> Scale Settings Exit </td> </tr> </table>	93.2°C	9.0b	126.5°C	Scale Settings Exit			<p>9 Press the Encoder Knob to quit the submenu.</p>
93.2°C	9.0b	126.5°C					
Scale Settings Exit							
<table border="1"> <tr> <td>93.2°C</td> <td>9.0b</td> <td>126.5°C</td> </tr> <tr> <td colspan="3" style="text-align: center;"> Exit Menu </td> </tr> </table>	93.2°C	9.0b	126.5°C	Exit Menu			<p>10 You must scroll to the exit menu to exit the programming mode, or press the Encoder Knob for 2 seconds.</p>
93.2°C	9.0b	126.5°C					
Exit Menu							

“Technical” Programming

Coffee Boiler

93.2°C	9.0b	126.5°C
Coffee Boiler Settings		

- This parameter enables the technician to set various parameters of the coffee boiler.
- The boiler temperature is measured in the boiler’s most critical point, where the temperature fluctuation is the largest.
- The temperature of the water inside the group head is kept constant by the group mass. Though the boiler temperature may fluctuate slightly, that of the water inside the group is constant.
- In order to properly calibrate the temperature of each espresso, it is important that you measure the temperature of the water inside the group using an external temperature measuring device. The difference between the temperature shown on the display and the measured temperature can be compensated with the “Coffee T. offset” parameter.

Display	Operating Procedure						
<table border="1"> <tr> <td>93.2°C</td> <td>9.0b</td> <td>126.5°C</td> </tr> <tr> <td colspan="3" style="text-align: center;"> Password 0000 </td> </tr> </table>	93.2°C	9.0b	126.5°C	Password 0000			<ol style="list-style-type: none"> 1 After entering the password and accessing the “Technician” programming menu, rotate the Encoder Knob until the following is displayed. 2 Press the Encoder Knob to access the menu. 3 Press the Encoder Knob to access the menu, rotate the Encoder Knob to choose between ENABLED and DISABLED, press the Encoder Knob to confirm the option. 4 Press the Encoder Knob to access the menu, rotate the Encoder Knob to modify the value, press the Encoder Knob to confirm the desired value.
93.2°C	9.0b	126.5°C					
Password 0000							
<table border="1"> <tr> <td>93.2°C</td> <td>9.0b</td> <td>126.5°C</td> </tr> <tr> <td colspan="3" style="text-align: center;"> Coffee Boiler Settings </td> </tr> </table>	93.2°C	9.0b	126.5°C	Coffee Boiler Settings			
93.2°C	9.0b	126.5°C					
Coffee Boiler Settings							
<table border="1"> <tr> <td>93.2°C</td> <td>9.0b</td> <td>126.5°C</td> </tr> <tr> <td colspan="3" style="text-align: center;"> Coffee Boiler 1 ENABLED </td> </tr> </table>	93.2°C	9.0b	126.5°C	Coffee Boiler 1 ENABLED			
93.2°C	9.0b	126.5°C					
Coffee Boiler 1 ENABLED							
<table border="1"> <tr> <td>93.2°C</td> <td>9.0b</td> <td>126.5°C</td> </tr> <tr> <td colspan="3" style="text-align: center;"> CB1 Temperature Current:94.5 Target:94.5 </td> </tr> </table>	93.2°C	9.0b	126.5°C	CB1 Temperature Current:94.5 Target:94.5			
93.2°C	9.0b	126.5°C					
CB1 Temperature Current:94.5 Target:94.5							

Coffee Boiler

93.2°C	9.0b	126.5°C
Coffee Boiler Settings		

- The OFFSET parameter is used to calibrate the coffee boiler system temperature, to ensure that the displayed temperature exactly corresponds to the temperature of the water in the group head.
- This parameter is factory preset according to the results of the initial tests on this espresso machine.
- We recommend that you don't change this value.
- Changing this value might lead to unexpected results.
- It is important that you take note of this value before you make any change, to ensure that you can restore the factory settings in case of unexpected results. Each machine might have a different value, as they are set individually.

Display	Operating Procedure						
<table border="1" style="width: 100%;"> <tr> <td>93.2°C</td> <td>9.0b</td> <td>126.5°C</td> </tr> <tr> <td colspan="3" style="text-align: center;">CB:1 Offset 3.5</td> </tr> </table>	93.2°C	9.0b	126.5°C	CB:1 Offset 3.5			<p>5 Press the Encoder Knob to access the menu, rotate the Encoder Knob to modify the value, press the Encoder Knob to confirm the desired value.</p>
93.2°C	9.0b	126.5°C					
CB:1 Offset 3.5							
<table border="1" style="width: 100%;"> <tr> <td>93.2°C</td> <td>9.0b</td> <td>126.5°C</td> </tr> <tr> <td colspan="3" style="text-align: center;">Coffee Boiler Exit</td> </tr> </table>	93.2°C	9.0b	126.5°C	Coffee Boiler Exit			<p>6 Press the Encoder Knob to quit the submenu.</p>
93.2°C	9.0b	126.5°C					
Coffee Boiler Exit							
<table border="1" style="width: 100%;"> <tr> <td>93.2°C</td> <td>9.0b</td> <td>126.5°C</td> </tr> <tr> <td colspan="3" style="text-align: center;">Exit Menu</td> </tr> </table>	93.2°C	9.0b	126.5°C	Exit Menu			<p>7 You must scroll to the exit menu to exit the programming mode, or press the Encoder Knob for 2 seconds.</p>
93.2°C	9.0b	126.5°C					
Exit Menu							

⚠ DANGER ⚠
**THE COFFEE BOILER CONTAINS WATER AT ELEVATED TEMPERATURES.
 WATER TEMPERATURE OVER 52°C CAN CAUSE SEVERE BURNS INSTANTLY OR DEATH FROM SCALDING.**

“Technical” Programming

Steam Boiler

93.2°C	9.0b	126.5°C
Steam Boiler Settings		

- This parameter enables the technician to set various parameters of the steam boiler.
- The temperature of saturated water is proportional to the pressure inside the Steam Boiler. Therefore it is possible to regulate the pressure of the steam boiler by means of electronic temperature control. Please use the following tables as reference when setting the steam boiler temperature.
- The maximum permitted value for the temperature setting is 129°C.
- The parameter filling WITH PUMP allows the technician to select the activation of the water pump during the automatic filling cycle of the service boiler.
- Only under unusual circumstances would the option of “WITHOUT PUMP” be chosen.

Display	Operating Procedure						
<table border="1"> <tr> <td>93.2°C</td> <td>9.0b</td> <td>126.5°C</td> </tr> <tr> <td colspan="3" style="text-align: center;"> Password 0000 </td> </tr> </table>	93.2°C	9.0b	126.5°C	Password 0000			1 After entering the password and accessing the “Technician” programming menu, rotate the Encoder Knob until the following is displayed.
93.2°C	9.0b	126.5°C					
Password 0000							
<table border="1"> <tr> <td>93.2°C</td> <td>9.0b</td> <td>126.5°C</td> </tr> <tr> <td colspan="3" style="text-align: center;"> Steam Boiler Settings </td> </tr> </table>	93.2°C	9.0b	126.5°C	Steam Boiler Settings			2 Press the Encoder Knob to access the menu.
93.2°C	9.0b	126.5°C					
Steam Boiler Settings							
<table border="1"> <tr> <td>93.2°C</td> <td>9.0b</td> <td>126.5°C</td> </tr> <tr> <td colspan="3" style="text-align: center;"> Steam Boiler ENABLED </td> </tr> </table>	93.2°C	9.0b	126.5°C	Steam Boiler ENABLED			3 Press the Encoder Knob to access the menu, rotate the Encoder Knob to choose between ENABLED and DISABLED , press the Encoder Knob to confirm the option.
93.2°C	9.0b	126.5°C					
Steam Boiler ENABLED							
<table border="1"> <tr> <td>93.2°C</td> <td>9.0b</td> <td>126.5°C</td> </tr> <tr> <td colspan="3" style="text-align: center;"> Temp. Vapore Attuale:124.4 Obiettivo:123.5 </td> </tr> </table>	93.2°C	9.0b	126.5°C	Temp. Vapore Attuale:124.4 Obiettivo:123.5			4 Press the Encoder Knob to access the menu, rotate the Encoder Knob to modify the value, press the Encoder Knob to confirm the desired value.
93.2°C	9.0b	126.5°C					
Temp. Vapore Attuale:124.4 Obiettivo:123.5							

Steam Boiler

93.2°C	9.0b	126.5°C
Steam Boiler Settings		

- The electronics installed in this espresso machine give priority to the brew boiler for pressure. The activation of the auto-fill cycle during the brewing process can reduce the overall dispensing pressure in the brew boiler.
- During the auto-fill cycle, if a brew cycle is chosen, the auto-fill cycle is delayed until all brew cycles are complete. • SAFETY TEST allows to bring the steam

- boiler temperature to 140°C, thus triggering the safety valve. Once the valve has triggered disable the function.
- Should the safety valve fail to trigger within approximately one minute of the temperature reaching 140°C, disable the function and replace the valve.
- Only qualified technicians can perform this operation.

Display	Operating Procedure						
<table border="1"> <tr> <td>93.2°C</td> <td>9.0b</td> <td>126.5°C</td> </tr> <tr> <td colspan="3" style="text-align: center;">Autofill Delay 2s start 2s stop</td> </tr> </table>	93.2°C	9.0b	126.5°C	Autofill Delay 2s start 2s stop			<p>5 The first value indicates the time in seconds between the detection of the need to fill and the start of filling. The second value indicates the time in seconds between filling and its actual end. Press the Encoder Knob to access the menu, rotate the Encoder Knob to set the desired automatic filling time, press the Encoder Knob to confirm the desired value.</p>
93.2°C	9.0b	126.5°C					
Autofill Delay 2s start 2s stop							
<table border="1"> <tr> <td>93.2°C</td> <td>9.0b</td> <td>126.5°C</td> </tr> <tr> <td colspan="3" style="text-align: center;">Fill During Brew YES</td> </tr> </table>	93.2°C	9.0b	126.5°C	Fill During Brew YES			<p>6 Press the Encoder Knob to access the menu, rotate the Encoder Knob to choose between YES and NO, press the Encoder Knob to confirm the option.</p>
93.2°C	9.0b	126.5°C					
Fill During Brew YES							
<table border="1"> <tr> <td>93.2°C</td> <td>9.0b</td> <td>126.5°C</td> </tr> <tr> <td colspan="3" style="text-align: center;">Autofill Timeout 10</td> </tr> </table>	93.2°C	9.0b	126.5°C	Autofill Timeout 10			<p>7 Press the Encoder Knob to access the menu, rotate the Encoder Knob to set the desired time, press the Encoder Knob to confirm the option.</p>
93.2°C	9.0b	126.5°C					
Autofill Timeout 10							
<table border="1"> <tr> <td>93.2°C</td> <td>9.0b</td> <td>126.5°C</td> </tr> <tr> <td colspan="3" style="text-align: center;">Fill With Pump WITH PUMP</td> </tr> </table>	93.2°C	9.0b	126.5°C	Fill With Pump WITH PUMP			<p>8 Press the Encoder Knob to access the menu, rotate the Encoder Knob to choose between WITH PUMP and WITHOUT PUMP, press the Encoder Knob to confirm the option.</p>
93.2°C	9.0b	126.5°C					
Fill With Pump WITH PUMP							

“Technical” Programming

Steam Boiler

93.2°C	9.0b	126.5°C
Steam Boiler Settings		

- DRAIN STEAM BOILER allows the service staff to renew or “regenerate” the water contained inside the steam boiler, discharging about one half of the water contained in the boiler.
- This procedure is recommended in case the machine should remain inactive for more than 8 hours and in any case at least on a weekly basis.

Display	Operating Procedure						
<table border="1"> <tr> <td>93.2°C</td> <td>9.0b</td> <td>126.5°C</td> </tr> <tr> <td colspan="3" style="text-align: center;"> Level Sensitivity HIGH </td> </tr> </table>	93.2°C	9.0b	126.5°C	Level Sensitivity HIGH			<p>9 Press the Encoder Knob to access the menu, rotate the Encoder Knob to choose between HIGH, LOW or MEDIUM, press the Encoder Knob to confirm the option.</p>
93.2°C	9.0b	126.5°C					
Level Sensitivity HIGH							
<table border="1"> <tr> <td>93.2°C</td> <td>9.0b</td> <td>126.5°C</td> </tr> <tr> <td colspan="3" style="text-align: center;"> Start Steam Boiler Safety Test </td> </tr> </table>	93.2°C	9.0b	126.5°C	Start Steam Boiler Safety Test			<p>10 Press the Encoder Knob to quit the submenu.</p>
93.2°C	9.0b	126.5°C					
Start Steam Boiler Safety Test							
<table border="1"> <tr> <td>93.2°C</td> <td>9.0b</td> <td>126.5°C</td> </tr> <tr> <td colspan="3" style="text-align: center;"> Drain Steam Boiler </td> </tr> </table>	93.2°C	9.0b	126.5°C	Drain Steam Boiler			<p>11 Press the Encoder Knob to enable the function.</p>
93.2°C	9.0b	126.5°C					
Drain Steam Boiler							
<table border="1"> <tr> <td>93.2°C</td> <td>9.0b</td> <td>126.5°C</td> </tr> <tr> <td colspan="3" style="text-align: center;"> Close Mixing Valve Enter when Done </td> </tr> </table>	93.2°C	9.0b	126.5°C	Close Mixing Valve Enter when Done			<p>12 Manually close the mixing valve to allow the drain of the water contained in the steam boiler.</p>
93.2°C	9.0b	126.5°C					
Close Mixing Valve Enter when Done							

Steam Boiler

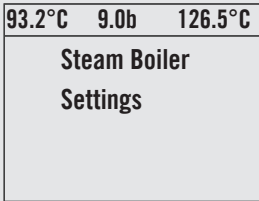

Display	Operating Procedure						
<table border="1"> <tr> <td>93.2°C</td> <td>9.0b</td> <td>126.5°C</td> </tr> <tr> <td colspan="3" style="text-align: center;"> Press Water Button Enter when Empty </td> </tr> </table>	93.2°C	9.0b	126.5°C	Press Water Button Enter when Empty			<p>13 Press the hot water button to start draining the water contained in the steam boiler. Press the Encoder Knob when the boiler is empty, wait for refilling completion.</p>
93.2°C	9.0b	126.5°C					
Press Water Button Enter when Empty							
<table border="1"> <tr> <td>93.2°C</td> <td>9.0b</td> <td>126.5°C</td> </tr> <tr> <td colspan="3" style="text-align: center;"> Reset Mixing Valve Enter when Done </td> </tr> </table>	93.2°C	9.0b	126.5°C	Reset Mixing Valve Enter when Done			<p>14 Manually reopen the mixing valve and press the Encoder Knob. Now the procedure to renew or “regenerate” the water inside the steam boiler is completed</p>
93.2°C	9.0b	126.5°C					
Reset Mixing Valve Enter when Done							
<table border="1"> <tr> <td>93.2°C</td> <td>9.0b</td> <td>126.5°C</td> </tr> <tr> <td colspan="3" style="text-align: center;"> Steam Boiler Exit </td> </tr> </table>	93.2°C	9.0b	126.5°C	Steam Boiler Exit			<p>15 Press the Encoder Knob to quit the submenu.</p>
93.2°C	9.0b	126.5°C					
Steam Boiler Exit							
<table border="1"> <tr> <td>93.2°C</td> <td>9.0b</td> <td>126.5°C</td> </tr> <tr> <td colspan="3" style="text-align: center;"> Exit Menu </td> </tr> </table>	93.2°C	9.0b	126.5°C	Exit Menu			<p>16 You must scroll to the exit menu to exit the programming mode, or press the Encoder Knob for 2 seconds.</p>
93.2°C	9.0b	126.5°C					
Exit Menu							



“Technical” Programming

Cup Warmer

93.2°C	9.0b	126.5°C
Cup Warmer ENABLED		

- This parameter allows the technician to enable or disable the cups heating function.
- This parameter allows the technician to adjust the operating time of the resistance for the heating of the cups.
- This function is displayed only on the models of espresso machine equipped with this accessory.
- In TIME mode it is possible also to stop and to restart the cycle of the cup warmer by pushing the cup warmer button.

Display	Operating Procedure						
<table border="1"> <tr> <td>93.2°C</td> <td>9.0b</td> <td>126.5°C</td> </tr> <tr> <td colspan="3" style="text-align: center;"> Password 0000 </td> </tr> </table>	93.2°C	9.0b	126.5°C	Password 0000			<ol style="list-style-type: none"> 1 After entering the password and accessing the “Technician” programming menu, rotate the Encoder Knob until the following is displayed. 2 Press the Encoder Knob to access the menu. 3 Press the Encoder Knob to access the menu, rotate the Encoder Knob to choose between ENABLED and DISABLED, press the Encoder Knob to confirm the option. 4 Press the Encoder Knob to access the menu, rotate the Encoder Knob to set the desired time, press the Encoder Knob to confirm the option.
93.2°C	9.0b	126.5°C					
Password 0000							
<table border="1"> <tr> <td>93.2°C</td> <td>9.0b</td> <td>126.5°C</td> </tr> <tr> <td colspan="3" style="text-align: center;"> Cup Warmer Settings </td> </tr> </table>	93.2°C	9.0b	126.5°C	Cup Warmer Settings			
93.2°C	9.0b	126.5°C					
Cup Warmer Settings							
<table border="1"> <tr> <td>93.2°C</td> <td>9.0b</td> <td>126.5°C</td> </tr> <tr> <td colspan="3" style="text-align: center;"> Cup Warmer ENABLED </td> </tr> </table>	93.2°C	9.0b	126.5°C	Cup Warmer ENABLED			
93.2°C	9.0b	126.5°C					
Cup Warmer ENABLED							
<table border="1"> <tr> <td>93.2°C</td> <td>9.0b</td> <td>126.5°C</td> </tr> <tr> <td colspan="3" style="text-align: center;"> Cup Warmer T On: 2 min T Off: 8 min </td> </tr> </table>	93.2°C	9.0b	126.5°C	Cup Warmer T On: 2 min T Off: 8 min			
93.2°C	9.0b	126.5°C					
Cup Warmer T On: 2 min T Off: 8 min							

Cup Warmer

93.2°C	9.0b	126.5°C
Cup Warmer ENABLED		

- This parameter allows the technician to enable or disable the cups heating function.
- This parameter allows the technician to adjust the operating time of the resistance for the heating of the cups.
- This function is displayed only on the models of espresso machine equipped with this accessory.
- In TIME mode it is possible also to stop and to restart the cycle of the cup warmer by pushing the cup warmer button.

Display	Operating Procedure						
<table border="1" style="width: 100%;"> <tr> <td>93.2°C</td> <td>9.0b</td> <td>126.5°C</td> </tr> <tr> <td colspan="3" style="text-align: center;"> Cup Warmer Mode TIME </td> </tr> </table>	93.2°C	9.0b	126.5°C	Cup Warmer Mode TIME			<p>5 Press the Encoder Knob to access the menu, rotate the Encoder Knob to choose between TIME and BY BUTTON, press the Encoder Knob to confirm the option.</p>
93.2°C	9.0b	126.5°C					
Cup Warmer Mode TIME							
<table border="1" style="width: 100%;"> <tr> <td>93.2°C</td> <td>9.0b</td> <td>126.5°C</td> </tr> <tr> <td colspan="3" style="text-align: center;"> Cup Warmer On Time: 5 min Off Time: 5 min </td> </tr> </table>	93.2°C	9.0b	126.5°C	Cup Warmer On Time: 5 min Off Time: 5 min			<p>6 You must scroll to the exit menu to exit the programming mode, or press the Encoder Knob for 2 seconds.</p>
93.2°C	9.0b	126.5°C					
Cup Warmer On Time: 5 min Off Time: 5 min							
<table border="1" style="width: 100%;"> <tr> <td>93.2°C</td> <td>9.0b</td> <td>126.5°C</td> </tr> <tr> <td colspan="3" style="text-align: center;"> Cup Warmer Exit </td> </tr> </table>	93.2°C	9.0b	126.5°C	Cup Warmer Exit			<p>7 Press the Encoder Knob to quit the submenu.</p>
93.2°C	9.0b	126.5°C					
Cup Warmer Exit							
<table border="1" style="width: 100%;"> <tr> <td>93.2°C</td> <td>9.0b</td> <td>126.5°C</td> </tr> <tr> <td colspan="3" style="text-align: center;"> Exit Menu </td> </tr> </table>	93.2°C	9.0b	126.5°C	Exit Menu			<p>8 You must scroll to the exit menu to exit the programming mode, or press the Encoder Knob for 2 seconds.</p>
93.2°C	9.0b	126.5°C					
Exit Menu							

“Technical” Programming

Auto ON/OFF

93.2°C	9.0b	126.5°C
Auto On/Off Settings		

- This parameter allows the technician to program the espresso machine to turn on at a preset time and turn off at a preset time.
- This feature also allows the espresso machine to remain in the off condition for one repeating closed day.

Display	Operating Procedure						
<table border="1"> <tr> <td>93.2°C</td> <td>9.0b</td> <td>126.5°C</td> </tr> <tr> <td colspan="3" style="text-align: center;">Password 0000</td> </tr> </table>	93.2°C	9.0b	126.5°C	Password 0000			<ol style="list-style-type: none"> 1 After entering the password and accessing the “Technician” programming menu, rotate the Encoder Knob until the following is displayed. 2 Press the Encoder Knob to access the menu. 3 Press the Encoder Knob to access the menu, rotate the Encoder Knob to choose between ENABLED and DISABLED, press the Encoder Knob to confirm the option. 4 Press the Encoder Knob to access the menu, rotate the Encoder Knob to modify the value, press the Encoder Knob to confirm the desired value.
93.2°C	9.0b	126.5°C					
Password 0000							
<table border="1"> <tr> <td>93.2°C</td> <td>9.0b</td> <td>126.5°C</td> </tr> <tr> <td colspan="3" style="text-align: center;">Auto On/Off Settings</td> </tr> </table>	93.2°C	9.0b	126.5°C	Auto On/Off Settings			
93.2°C	9.0b	126.5°C					
Auto On/Off Settings							
<table border="1"> <tr> <td>93.2°C</td> <td>9.0b</td> <td>126.5°C</td> </tr> <tr> <td colspan="3" style="text-align: center;">Auto On/Off ENABLED</td> </tr> </table>	93.2°C	9.0b	126.5°C	Auto On/Off ENABLED			
93.2°C	9.0b	126.5°C					
Auto On/Off ENABLED							
<table border="1"> <tr> <td>93.2°C</td> <td>9.0b</td> <td>126.5°C</td> </tr> <tr> <td colspan="3" style="text-align: center;">On Time 00:00</td> </tr> </table>	93.2°C	9.0b	126.5°C	On Time 00:00			
93.2°C	9.0b	126.5°C					
On Time 00:00							

Auto ON/OFF

93.2°C	9.0b	126.5°C
Auto On/Off Settings		

- This parameter allows the technician to program the espresso machine to turn on at a preset time and turn off at a preset time.
- This feature also allows the espresso machine to remain in the off condition for one repeating closed day.

Display	Operating Procedure						
<table border="1" style="width: 100%;"> <tr> <td>93.2°C</td> <td>9.0b</td> <td>126.5°C</td> </tr> <tr> <td colspan="3" style="text-align: center;"> Off Time 00:00 </td> </tr> </table>	93.2°C	9.0b	126.5°C	Off Time 00:00			<p>5 Press the Encoder Knob to access the menu, rotate the Encoder Knob to modify the value, press the Encoder Knob to confirm the desired value.</p>
93.2°C	9.0b	126.5°C					
Off Time 00:00							
<table border="1" style="width: 100%;"> <tr> <td>93.2°C</td> <td>9.0b</td> <td>126.5°C</td> </tr> <tr> <td colspan="3" style="text-align: center;"> Closed On NEVER </td> </tr> </table>	93.2°C	9.0b	126.5°C	Closed On NEVER			<p>6 Press the Encoder Knob to enter the menu, rotate the Encoder Knob to select an option, press the Encoder Knob to confirm the option.</p>
93.2°C	9.0b	126.5°C					
Closed On NEVER							
<table border="1" style="width: 100%;"> <tr> <td>93.2°C</td> <td>9.0b</td> <td>126.5°C</td> </tr> <tr> <td colspan="3" style="text-align: center;"> Auto On/Off Exit </td> </tr> </table>	93.2°C	9.0b	126.5°C	Auto On/Off Exit			<p>7 Press the Encoder Knob to quit the submenu.</p>
93.2°C	9.0b	126.5°C					
Auto On/Off Exit							
<table border="1" style="width: 100%;"> <tr> <td>93.2°C</td> <td>9.0b</td> <td>126.5°C</td> </tr> <tr> <td colspan="3" style="text-align: center;"> Exit Menu </td> </tr> </table>	93.2°C	9.0b	126.5°C	Exit Menu			<p>8 You must scroll to the exit menu to exit the programming mode, or press the Encoder Knob for 2 seconds.</p>
93.2°C	9.0b	126.5°C					
Exit Menu							



“Technical” Programming

Clock Adjust

93.2°C	9.0b	126.5°C
Clock Time		
16:30 TUESDAY		

- This parameter allows the user to set the time of day and the day of the week.
- This parameter is used to display time and is also used by the “Auto On/Off” parameter
- There are 4 changeable values within this parameter:
 - Hour;
 - Minute;
 - Day of week;
 - Hour Format 12h or 24h.

Display	Operating Procedure						
<table border="1"> <tr> <td>93.2°C</td> <td>9.0b</td> <td>126.5°C</td> </tr> <tr> <td colspan="3" style="text-align: center;">Password 0000</td> </tr> </table>	93.2°C	9.0b	126.5°C	Password 0000			<p>1 After entering the password and accessing the “Technician” programming menu, rotate the Encoder Knob until the following is displayed.</p> <p>2 Press the Encoder Knob once to set the first value, rotate the Encoder Knob to set the desired time, press the Encoder Knob twice to set the minutes, rotate the Encoder Knob to set the desired value. Press the Encoder Knob thrice to set the day of the week, rotate the Encoder Knob to set the desired day.</p> <p>3 You must scroll to the exit menu to exit the programming mode, or press the Encoder Knob for 2 seconds.</p>
93.2°C	9.0b	126.5°C					
Password 0000							
<table border="1"> <tr> <td>93.2°C</td> <td>9.0b</td> <td>126.5°C</td> </tr> <tr> <td colspan="3" style="text-align: center;">Clock Time 16:30 TUESDAY</td> </tr> </table>	93.2°C	9.0b	126.5°C	Clock Time 16:30 TUESDAY			
93.2°C	9.0b	126.5°C					
Clock Time 16:30 TUESDAY							
<table border="1"> <tr> <td>93.2°C</td> <td>9.0b</td> <td>126.5°C</td> </tr> <tr> <td colspan="3" style="text-align: center;">Exit Menu</td> </tr> </table>	93.2°C	9.0b	126.5°C	Exit Menu			
93.2°C	9.0b	126.5°C					
Exit Menu							

ECO Mode

93.2°C	9.0b	126.5°C
Eco Mode Settings		

- This parameter allows the technician to set up a temperature to be maintained in case of a temporary non utilization of the espresso machine.

Display	Operating Procedure						
<table border="1" style="width: 100%;"> <tr> <td>93.2°C</td> <td>9.0b</td> <td>126.5°C</td> </tr> <tr> <td colspan="3" style="text-align: center;">Password 0000</td> </tr> </table>	93.2°C	9.0b	126.5°C	Password 0000			<ol style="list-style-type: none"> 1 After entering the password and accessing the “Technician” programming menu, rotate the Encoder Knob until the following is displayed. 2 Press the Encoder Knob to access the menu. 3 Press the Encoder Knob to access the menu, rotate the Encoder Knob to set the desired temperature, press the Encoder Knob to confirm the value. 4 Press the Encoder Knob to access the menu, rotate the Encoder Knob to set the desired time in minutes, press the Encoder Knob to confirm the value. Setting the value to “0” (zero) will disable the Eco Mode parameter.
93.2°C	9.0b	126.5°C					
Password 0000							
<table border="1" style="width: 100%;"> <tr> <td>93.2°C</td> <td>9.0b</td> <td>126.5°C</td> </tr> <tr> <td colspan="3" style="text-align: center;">Eco Mode Settings</td> </tr> </table>	93.2°C	9.0b	126.5°C	Eco Mode Settings			
93.2°C	9.0b	126.5°C					
Eco Mode Settings							
<table border="1" style="width: 100%;"> <tr> <td>93.2°C</td> <td>9.0b</td> <td>126.5°C</td> </tr> <tr> <td colspan="3" style="text-align: center;">Eco Mode Temperature: -10</td> </tr> </table>	93.2°C	9.0b	126.5°C	Eco Mode Temperature: -10			
93.2°C	9.0b	126.5°C					
Eco Mode Temperature: -10							
<table border="1" style="width: 100%;"> <tr> <td>93.2°C</td> <td>9.0b</td> <td>126.5°C</td> </tr> <tr> <td colspan="3" style="text-align: center;">Auto Eco Time 0</td> </tr> </table>	93.2°C	9.0b	126.5°C	Auto Eco Time 0			
93.2°C	9.0b	126.5°C					
Auto Eco Time 0							

“Technical” Programming

ECO Mode

93.2°C	9.0b	126.5°C
Eco Mode Settings		

- This parameter allows the technician to set up a temperature to be maintained in case of a temporary non utilization of the espresso machine.

Display	Operating Procedure						
<table border="1"><tr><td>93.2°C</td><td>9.0b</td><td>126.5°C</td></tr><tr><td colspan="3">Eco Mode Exit</td></tr></table>	93.2°C	9.0b	126.5°C	Eco Mode Exit			5 Press the Encoder Knob to quit the submenu.
93.2°C	9.0b	126.5°C					
Eco Mode Exit							
<table border="1"><tr><td>93.2°C</td><td>9.0b</td><td>126.5°C</td></tr><tr><td colspan="3">Exit Menu</td></tr></table>	93.2°C	9.0b	126.5°C	Exit Menu			6 You must scroll to the exit menu to exit the programming mode, or press the Encoder Knob for 2 seconds.
93.2°C	9.0b	126.5°C					
Exit Menu							

Filter Alarm

93.2°C	9.0b	126.5°C
Water Filter Alarm Settings		

- This parameter enables the technician to program an alarm that will alert the user about the need for maintenance or replacement of the water filter.
- Once the set volume has been reached, the error message “Filter Alarm” will be displayed.
- A value of 0 (zero) disables the filter alarm parameter.
- This feature can be enabled or disabled.

Display	Operating Procedure						
<table border="1" style="width: 100%; border-collapse: collapse;"> <tr> <td>93.2°C</td> <td>9.0b</td> <td>126.5°C</td> </tr> <tr> <td colspan="3" style="text-align: center;"> Password 0000 </td> </tr> </table>	93.2°C	9.0b	126.5°C	Password 0000			<ol style="list-style-type: none"> 1 After entering the password and accessing the “Technician” programming menu, rotate the Encoder Knob until the following is displayed. 2 Press the Encoder Knob to access the menu. 3 Press the Encoder Knob to access the menu, rotate the Encoder Knob to choose between ENABLED and DISABLED, press the Encoder Knob to confirm the option. 4 Press the Encoder Knob to access the menu, rotate the Encoder Knob to modify the value, press the Encoder Knob to confirm the desired value.
93.2°C	9.0b	126.5°C					
Password 0000							
<table border="1" style="width: 100%; border-collapse: collapse;"> <tr> <td>93.2°C</td> <td>9.0b</td> <td>126.5°C</td> </tr> <tr> <td colspan="3" style="text-align: center;"> Water Filter Alarm Settings </td> </tr> </table>	93.2°C	9.0b	126.5°C	Water Filter Alarm Settings			
93.2°C	9.0b	126.5°C					
Water Filter Alarm Settings							
<table border="1" style="width: 100%; border-collapse: collapse;"> <tr> <td>93.2°C</td> <td>9.0b</td> <td>126.5°C</td> </tr> <tr> <td colspan="3" style="text-align: center;"> Water Filter Alarm DISABLED </td> </tr> </table>	93.2°C	9.0b	126.5°C	Water Filter Alarm DISABLED			
93.2°C	9.0b	126.5°C					
Water Filter Alarm DISABLED							
<table border="1" style="width: 100%; border-collapse: collapse;"> <tr> <td>93.2°C</td> <td>9.0b</td> <td>126.5°C</td> </tr> <tr> <td colspan="3" style="text-align: center;"> Water Filter Alarm Usata: 1000L Limite: 5000L </td> </tr> </table>	93.2°C	9.0b	126.5°C	Water Filter Alarm Usata: 1000L Limite: 5000L			
93.2°C	9.0b	126.5°C					
Water Filter Alarm Usata: 1000L Limite: 5000L							

“Technical” Programming

Filter Alarm

93.2°C	9.0b	126.5°C
Water Filter Alarm Settings		

- This parameter enables the technician to program an alarm that will alert the user about the need for maintenance or replacement of the water filter.
- Once the set volume has been reached, the error message “Filter Alarm” will be displayed.
- A value of 0 (zero) disables the filter alarm parameter.
- This feature can be enabled or disabled.

Display	Operating Procedure						
<table border="1"> <tr> <td>93.2°C</td> <td>9.0b</td> <td>126.5°C</td> </tr> <tr> <td colspan="3" style="text-align: center;"> Water Percentage 40% </td> </tr> </table>	93.2°C	9.0b	126.5°C	Water Percentage 40%			<p>5 Press the Encoder Knob to access the menu, rotate the Encoder Knob to modify the value, press the Encoder Knob to confirm the desired value.</p> <p>6 Press the Encoder Knob to reset the settings made.</p> <p>7 Press the Encoder Knob to quit the submenu.</p> <p>8 You must scroll to the exit menu to exit the programming mode, or press the Encoder Knob for 2 seconds.</p>
93.2°C	9.0b	126.5°C					
Water Percentage 40%							
<table border="1"> <tr> <td>93.2°C</td> <td>9.0b</td> <td>126.5°C</td> </tr> <tr> <td colspan="3" style="text-align: center;"> Reset Filter Alarm </td> </tr> </table>	93.2°C	9.0b	126.5°C	Reset Filter Alarm			
93.2°C	9.0b	126.5°C					
Reset Filter Alarm							
<table border="1"> <tr> <td>93.2°C</td> <td>9.0b</td> <td>126.5°C</td> </tr> <tr> <td colspan="3" style="text-align: center;"> Water Filter Alarm Exit </td> </tr> </table>	93.2°C	9.0b	126.5°C	Water Filter Alarm Exit			
93.2°C	9.0b	126.5°C					
Water Filter Alarm Exit							
<table border="1"> <tr> <td>93.2°C</td> <td>9.0b</td> <td>126.5°C</td> </tr> <tr> <td colspan="3" style="text-align: center;"> Exit Menu </td> </tr> </table>	93.2°C	9.0b	126.5°C	Exit Menu			
93.2°C	9.0b	126.5°C					
Exit Menu							

Coffee Doses Counter

93.2°C	9.0b	126.5°C
Coffee Doses Counter		

- This parameter allows the technician to review the total doses dispensed for each button.
- This parameter displays different values:
 - Total coffee doses;
 - Coffee doses for each button;
 - Hot water doses.

Display	Operating Procedure						
<table border="1"> <tr> <td>93.2°C</td> <td>9.0b</td> <td>126.5°C</td> </tr> <tr> <td colspan="3" style="text-align: center;"> Password 0000 </td> </tr> </table>	93.2°C	9.0b	126.5°C	Password 0000			<ol style="list-style-type: none"> 1 After entering the password and accessing the “Technician” programming menu, rotate the Encoder Knob until the following is displayed. 2 Press the Encoder Knob to access the menu. 3 Total dose display. Rotate the Encoder Knob to display the other doses. 4 Keep rotating the Encoder Knob to display the total doses of the individual groups.
93.2°C	9.0b	126.5°C					
Password 0000							
<table border="1"> <tr> <td>93.2°C</td> <td>9.0b</td> <td>126.5°C</td> </tr> <tr> <td colspan="3" style="text-align: center;"> Coffee Doses Counter </td> </tr> </table>	93.2°C	9.0b	126.5°C	Coffee Doses Counter			
93.2°C	9.0b	126.5°C					
Coffee Doses Counter							
<table border="1"> <tr> <td>93.2°C</td> <td>9.0b</td> <td>126.5°C</td> </tr> <tr> <td colspan="3" style="text-align: center;"> Total Coffee Doses:14 </td> </tr> </table>	93.2°C	9.0b	126.5°C	Total Coffee Doses:14			
93.2°C	9.0b	126.5°C					
Total Coffee Doses:14							
<table border="1"> <tr> <td>93.2°C</td> <td>9.0b</td> <td>126.5°C</td> </tr> <tr> <td colspan="3" style="text-align: center;"> G1 Doses 6 </td> </tr> </table>	93.2°C	9.0b	126.5°C	G1 Doses 6			
93.2°C	9.0b	126.5°C					
G1 Doses 6							

“Technical” Programming

Coffee Doses Counter

93.2°C	9.0b	126.5°C
Coffee Doses Counter		

- This parameter allows the technician to review the total doses dispensed for each button.
- This parameter displays different values:
 - Total coffee doses;
 - Coffee doses for each button;
 - Hot water doses.

Display	Operating Procedure									
<table border="1" style="width: 100%;"> <tr> <td>93.2°C</td> <td>9.0b</td> <td>126.5°C</td> </tr> <tr> <td colspan="3" style="text-align: center;">Left Steam Doses</td> </tr> <tr> <td colspan="3" style="text-align: center;">4</td> </tr> </table>	93.2°C	9.0b	126.5°C	Left Steam Doses			4			<p>5 Keep rotating the Encoder Knob to display the total doses of the individual steam wands.</p> <p>6 Keep rotating the Encoder Knob to also display the hot water button doses.</p> <p>7 Press the Encoder Knob to quit the submenu.</p>
93.2°C	9.0b	126.5°C								
Left Steam Doses										
4										
<table border="1" style="width: 100%;"> <tr> <td>93.2°C</td> <td>9.0b</td> <td>126.5°C</td> </tr> <tr> <td colspan="3" style="text-align: center;">Right Steam Doses</td> </tr> <tr> <td colspan="3" style="text-align: center;">6</td> </tr> </table>	93.2°C	9.0b	126.5°C	Right Steam Doses			6			
93.2°C	9.0b	126.5°C								
Right Steam Doses										
6										
<table border="1" style="width: 100%;"> <tr> <td>93.2°C</td> <td>9.0b</td> <td>126.5°C</td> </tr> <tr> <td colspan="3" style="text-align: center;">Water Dose</td> </tr> <tr> <td colspan="3" style="text-align: center;">10</td> </tr> </table>	93.2°C	9.0b	126.5°C	Water Dose			10			
93.2°C	9.0b	126.5°C								
Water Dose										
10										
<table border="1" style="width: 100%;"> <tr> <td>93.2°C</td> <td>9.0b</td> <td>126.5°C</td> </tr> <tr> <td colspan="3" style="text-align: center;">Coffee Doses</td> </tr> <tr> <td colspan="3" style="text-align: center;">Exit</td> </tr> </table>	93.2°C	9.0b	126.5°C	Coffee Doses			Exit			
93.2°C	9.0b	126.5°C								
Coffee Doses										
Exit										

Displaying the Firmware

93.2°C	9.0b	126.5°C
Electronics Settings		

- This parameter allows the technician to display the hardware and firmware version for all the electronic boards installed on the espresso machine.

Display	Operating Procedure						
<table border="1"> <tr> <td>93.2°C</td> <td>9.0b</td> <td>126.5°C</td> </tr> <tr> <td colspan="3" style="text-align: center;"> Password 0000 </td> </tr> </table>	93.2°C	9.0b	126.5°C	Password 0000			<ol style="list-style-type: none"> 1 After entering the password and accessing the “Technician” programming menu, rotate the Encoder Knob until the following is displayed. 2 Press the Encoder Knob to access the menu. 3 Press the Encoder Knob to access the menu, rotate the Encoder Knob to choose between ENABLED and DISABLED, press the Encoder Knob to confirm the option. 4 Rotate the Encoder Knob to display the hardware and firmware version for the Steam Board.
93.2°C	9.0b	126.5°C					
Password 0000							
<table border="1"> <tr> <td>93.2°C</td> <td>9.0b</td> <td>126.5°C</td> </tr> <tr> <td colspan="3" style="text-align: center;"> Electronics Settings </td> </tr> </table>	93.2°C	9.0b	126.5°C	Electronics Settings			
93.2°C	9.0b	126.5°C					
Electronics Settings							
<table border="1"> <tr> <td>93.2°C</td> <td>9.0b</td> <td>126.5°C</td> </tr> <tr> <td colspan="3" style="text-align: center;"> Force FW Upgrade On Next Startup DISABLED </td> </tr> </table>	93.2°C	9.0b	126.5°C	Force FW Upgrade On Next Startup DISABLED			
93.2°C	9.0b	126.5°C					
Force FW Upgrade On Next Startup DISABLED							
<table border="1"> <tr> <td>93.2°C</td> <td>9.0b</td> <td>126.5°C</td> </tr> <tr> <td colspan="3" style="text-align: center;"> Steam Board FW v3.0.1 HW v2.1 </td> </tr> </table>	93.2°C	9.0b	126.5°C	Steam Board FW v3.0.1 HW v2.1			
93.2°C	9.0b	126.5°C					
Steam Board FW v3.0.1 HW v2.1							

“Technical” Programming

Displaying the Firmware

93.2°C	9.0b	126.5°C
Electronics Settings		

- This parameter allows the technician to display the hardware and firmware version for all the electronic boards installed on the espresso machine.

Display	Operating Procedure						
<table border="1"> <tr> <td>93.2°C</td> <td>9.0b</td> <td>126.5°C</td> </tr> <tr> <td colspan="3" style="text-align: center;"> Profile Board FW v0.2.0 HW v2.4 </td> </tr> </table>	93.2°C	9.0b	126.5°C	Profile Board FW v0.2.0 HW v2.4			<p>5 Ruotare la Manopola Encoder per visualizzare la versione dell’hardware e firmware della Strada EP Board.</p>
93.2°C	9.0b	126.5°C					
Profile Board FW v0.2.0 HW v2.4							
<table border="1"> <tr> <td>93.2°C</td> <td>9.0b</td> <td>126.5°C</td> </tr> <tr> <td colspan="3" style="text-align: center;"> Universal Board HW v3.2 </td> </tr> </table>	93.2°C	9.0b	126.5°C	Universal Board HW v3.2			<p>6 Rotate the Encoder Knob to display the hardware version for the Universal Board.</p>
93.2°C	9.0b	126.5°C					
Universal Board HW v3.2							
<table border="1"> <tr> <td>93.2°C</td> <td>9.0b</td> <td>126.5°C</td> </tr> <tr> <td colspan="3" style="text-align: center;"> G1 Display FW v0.6.0 HW v3.2 </td> </tr> </table>	93.2°C	9.0b	126.5°C	G1 Display FW v0.6.0 HW v3.2			<p>7 Rotate the Encoder Knob to display the hardware and firmware version for the Graphic Display Board of each individual group.</p>
93.2°C	9.0b	126.5°C					
G1 Display FW v0.6.0 HW v3.2							
<table border="1"> <tr> <td>93.2°C</td> <td>9.0b</td> <td>126.5°C</td> </tr> <tr> <td colspan="3" style="text-align: center;"> Electronics Exit </td> </tr> </table>	93.2°C	9.0b	126.5°C	Electronics Exit			<p>8 Press the Encoder Knob to quit the submenu.</p>
93.2°C	9.0b	126.5°C					
Electronics Exit							

Display Brightness

93.2°C	9.0b	126.5°C
Display Brightness MEDIUM		

- This parameter allows the operator to adjust the brightness of the screen.

Display	Operating Procedure						
<table border="1" style="width: 100%;"> <tr> <td>93.2°C</td> <td>9.0b</td> <td>126.5°C</td> </tr> <tr> <td colspan="3" style="text-align: center;"> Password 0000 </td> </tr> </table>	93.2°C	9.0b	126.5°C	Password 0000			<ol style="list-style-type: none"> 1 After entering the password and accessing the “Technician” programming menu, rotate the Encoder Knob until the following is displayed. 2 Press the Encoder Knob to access the menu, rotate the Encoder Knob to choose between LOW, MEDIUM and HIGH, press the Encoder Knob to confirm the option. 3 You must scroll to the exit menu to exit the programming mode, or press the Encoder Knob for 2 seconds.
93.2°C	9.0b	126.5°C					
Password 0000							
<table border="1" style="width: 100%;"> <tr> <td>93.2°C</td> <td>9.0b</td> <td>126.5°C</td> </tr> <tr> <td colspan="3" style="text-align: center;"> Display Brightness MEDIUM </td> </tr> </table>	93.2°C	9.0b	126.5°C	Display Brightness MEDIUM			
93.2°C	9.0b	126.5°C					
Display Brightness MEDIUM							
<table border="1" style="width: 100%;"> <tr> <td>93.2°C</td> <td>9.0b</td> <td>126.5°C</td> </tr> <tr> <td colspan="3" style="text-align: center;"> Exit Menu </td> </tr> </table>	93.2°C	9.0b	126.5°C	Exit Menu			
93.2°C	9.0b	126.5°C					
Exit Menu							

“Technical” Programming

Display AutoDim

93.2°C	9.0b	126.5°C
Display AutoDim		
ENABLED		

- This parameter allows the operator to set the reduction of the screen brightness after a period of inactivity of the machine.
- This feature can be enabled or disabled.

Display	Operating Procedure									
<table border="1"> <tr> <td>93.2°C</td> <td>9.0b</td> <td>126.5°C</td> </tr> <tr> <td colspan="3">Password</td> </tr> <tr> <td colspan="3">0000</td> </tr> </table>	93.2°C	9.0b	126.5°C	Password			0000			<ol style="list-style-type: none"> 1 After entering the password and accessing the “Technician” programming menu, rotate the Encoder Knob until the following is displayed. 2 Press the Encoder Knob to access the menu, rotate the Encoder Knob to choose between ENABLED and DISABLED, press the Encoder Knob to confirm the option. 3 You must scroll to the exit menu to exit the programming mode, or press the Encoder Knob for 2 seconds.
93.2°C	9.0b	126.5°C								
Password										
0000										
<table border="1"> <tr> <td>93.2°C</td> <td>9.0b</td> <td>126.5°C</td> </tr> <tr> <td colspan="3">Display AutoDim</td> </tr> <tr> <td colspan="3">ENABLED</td> </tr> </table>	93.2°C	9.0b	126.5°C	Display AutoDim			ENABLED			
93.2°C	9.0b	126.5°C								
Display AutoDim										
ENABLED										
<table border="1"> <tr> <td>93.2°C</td> <td>9.0b</td> <td>126.5°C</td> </tr> <tr> <td colspan="3">Exit</td> </tr> <tr> <td colspan="3">Menu</td> </tr> </table>	93.2°C	9.0b	126.5°C	Exit			Menu			
93.2°C	9.0b	126.5°C								
Exit										
Menu										

Reset Pressure Guides

93.2°C	9.0b	126.5°C
Reset Profiles		

- This parameter allows the operator to reset the pressure guide profiles to the original factory settings.

Display	Operating Procedure						
<table border="1"> <tr> <td>93.2°C</td> <td>9.0b</td> <td>126.5°C</td> </tr> <tr> <td colspan="3"> Password 0000 </td> </tr> </table>	93.2°C	9.0b	126.5°C	Password 0000			<ol style="list-style-type: none"> 1 After entering the password and accessing the “Technician” programming menu, rotate the Encoder Knob until the following is displayed. 2 Press the Encoder Knob to access the menu. 3 Press the Encoder Knob to reset the settings. 4 Reset in progress.
93.2°C	9.0b	126.5°C					
Password 0000							
<table border="1"> <tr> <td>93.2°C</td> <td>9.0b</td> <td>126.5°C</td> </tr> <tr> <td colspan="3"> Reset Profiles </td> </tr> </table>	93.2°C	9.0b	126.5°C	Reset Profiles			
93.2°C	9.0b	126.5°C					
Reset Profiles							
<table border="1"> <tr> <td>93.2°C</td> <td>9.0b</td> <td>126.5°C</td> </tr> <tr> <td colspan="3"> Do you want to Reset Profiles? </td> </tr> </table>	93.2°C	9.0b	126.5°C	Do you want to Reset Profiles?			
93.2°C	9.0b	126.5°C					
Do you want to Reset Profiles?							
<table border="1"> <tr> <td>93.2°C</td> <td>9.0b</td> <td>126.5°C</td> </tr> <tr> <td colspan="3"> Cancelling... Resetting Profiles... </td> </tr> </table>	93.2°C	9.0b	126.5°C	Cancelling... Resetting Profiles...			
93.2°C	9.0b	126.5°C					
Cancelling... Resetting Profiles...							

“Technical” Programming

Pressure Guides

93.2°C	9.0b	126.5°C
Load Profiles From USB		

- This parameter allows the technician to load some guide profiles from the USB pendrive.

Display	Operating Procedure						
<table border="1"> <tr> <td>93.2°C</td> <td>9.0b</td> <td>126.5°C</td> </tr> <tr> <td colspan="3" style="text-align: center;"> Password 0000 </td> </tr> </table>	93.2°C	9.0b	126.5°C	Password 0000			<ol style="list-style-type: none"> 1 After entering the password and accessing the “Technician” programming menu, rotate the Encoder Knob until the following is displayed. 2 Press the Encoder Knob to access the menu. 3 Insert the USB Pendrive into the USB port and press the Encoder Knob. 4 You must scroll to the exit menu to exit the programming mode, or press the Encoder Knob for 2 seconds.
93.2°C	9.0b	126.5°C					
Password 0000							
<table border="1"> <tr> <td>93.2°C</td> <td>9.0b</td> <td>126.5°C</td> </tr> <tr> <td colspan="3" style="text-align: center;"> Load Profiles From USB </td> </tr> </table>	93.2°C	9.0b	126.5°C	Load Profiles From USB			
93.2°C	9.0b	126.5°C					
Load Profiles From USB							
<table border="1"> <tr> <td>93.2°C</td> <td>9.0b</td> <td>126.5°C</td> </tr> <tr> <td colspan="3" style="text-align: center;"> Insert USB Key </td> </tr> </table>	93.2°C	9.0b	126.5°C	Insert USB Key			
93.2°C	9.0b	126.5°C					
Insert USB Key							
<table border="1"> <tr> <td>93.2°C</td> <td>9.0b</td> <td>126.5°C</td> </tr> <tr> <td colspan="3" style="text-align: center;"> Exit Menu </td> </tr> </table>	93.2°C	9.0b	126.5°C	Exit Menu			
93.2°C	9.0b	126.5°C					
Exit Menu							

Pressure Guides

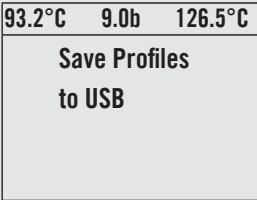

- This parameter allows the technician to save the guide profiles on the USB pendrive.

Display	Operating Procedure
<p>A screenshot of a device display showing the temperature values (93.2°C, 9.0b, 126.5°C) at the top and 'Password 0000' in the center.</p>	<p>1 After entering the password and accessing the “Technician” programming menu, rotate the Encoder Knob until the following is displayed.</p>
<p>A screenshot of a device display showing the temperature values (93.2°C, 9.0b, 126.5°C) at the top and 'Save Pressure Guides To USB' in the center.</p>	<p>2 Press the Encoder Knob to access the menu.</p>
<p>A screenshot of a device display showing the temperature values (93.2°C, 9.0b, 126.5°C) at the top and 'Insert USB Key' in the center.</p>	<p>3 Insert the USB Pendrive into the USB port and press the Encoder Knob.</p>
<p>A screenshot of a device display showing the temperature values (93.2°C, 9.0b, 126.5°C) at the top and 'Exit Menu' in the center.</p>	<p>4 You must scroll to the exit menu to exit the programming mode, or press the Encoder Knob for 2 seconds.</p>

“Technical” Programming

Pressure Guides

93.2°C	9.0b	126.5°C
Save and Load USB Settings		

- This parameter allows the technician to save and load some guide profiles from the USB pendrive.

Display	Operating Procedure						
<table border="1"> <tr> <td>93.2°C</td> <td>9.0b</td> <td>126.5°C</td> </tr> <tr> <td colspan="3" style="text-align: center;"> Password 0000 </td> </tr> </table>	93.2°C	9.0b	126.5°C	Password 0000			<ol style="list-style-type: none"> 1 After entering the password and accessing the “Technician” programming menu, rotate the Encoder Knob until the following is displayed. 2 Press the Encoder Knob to access the menu. 3 Press the Encoder Knob to access the menu. 4 Insert the USB Pendrive into the USB port and press the Encoder Knob.
93.2°C	9.0b	126.5°C					
Password 0000							
<table border="1"> <tr> <td>93.2°C</td> <td>9.0b</td> <td>126.5°C</td> </tr> <tr> <td colspan="3" style="text-align: center;"> Save and Load USB Settings </td> </tr> </table>	93.2°C	9.0b	126.5°C	Save and Load USB Settings			
93.2°C	9.0b	126.5°C					
Save and Load USB Settings							
<table border="1"> <tr> <td>93.2°C</td> <td>9.0b</td> <td>126.5°C</td> </tr> <tr> <td colspan="3" style="text-align: center;"> Load Settings From USB </td> </tr> </table>	93.2°C	9.0b	126.5°C	Load Settings From USB			
93.2°C	9.0b	126.5°C					
Load Settings From USB							
<table border="1"> <tr> <td>93.2°C</td> <td>9.0b</td> <td>126.5°C</td> </tr> <tr> <td colspan="3" style="text-align: center;"> Insert USB Key </td> </tr> </table>	93.2°C	9.0b	126.5°C	Insert USB Key			
93.2°C	9.0b	126.5°C					
Insert USB Key							

Reset

93.2°C	9.0b	126.5°C
Reset Settings		

- This parameter allows the technician to reset all the values returning to initial factory settings.
- It is possible to reset the settings you made in the “Barista” programming or the settings you made in the “Technical” programming.

Display	Operating Procedure						
<table border="1"> <tr> <td>93.2°C</td> <td>9.0b</td> <td>126.5°C</td> </tr> <tr> <td colspan="3"> Password 0000 </td> </tr> </table>	93.2°C	9.0b	126.5°C	Password 0000			<ol style="list-style-type: none"> 1 After entering the password and accessing the “Technician” programming menu, rotate the Encoder Knob until the following is displayed. 2 Press the Encoder Knob to access the menu. 3 Press the Encoder Knob to reset the settings made in the "Barista" programming. 4 Press the Encoder Knob to reset the settings made in the "Technician" programming.
93.2°C	9.0b	126.5°C					
Password 0000							
<table border="1"> <tr> <td>93.2°C</td> <td>9.0b</td> <td>126.5°C</td> </tr> <tr> <td colspan="3"> Reset Settings </td> </tr> </table>	93.2°C	9.0b	126.5°C	Reset Settings			
93.2°C	9.0b	126.5°C					
Reset Settings							
<table border="1"> <tr> <td>93.2°C</td> <td>9.0b</td> <td>126.5°C</td> </tr> <tr> <td colspan="3"> Barista Settings Reset </td> </tr> </table>	93.2°C	9.0b	126.5°C	Barista Settings Reset			
93.2°C	9.0b	126.5°C					
Barista Settings Reset							
<table border="1"> <tr> <td>93.2°C</td> <td>9.0b</td> <td>126.5°C</td> </tr> <tr> <td colspan="3"> Technician Settings Reset </td> </tr> </table>	93.2°C	9.0b	126.5°C	Technician Settings Reset			
93.2°C	9.0b	126.5°C					
Technician Settings Reset							

“Technical” Programming

Reset

93.2°C	9.0b	126.5°C
Reset Settings		

- This parameter allows the technician to reset all the values returning to initial factory settings.
- It is possible to reset the settings you made in the “Barista” programming or the settings you made in the “Technical” programming.

Display	Operating Procedure						
<table border="1"><tr><td>93.2°C</td><td>9.0b</td><td>126.5°C</td></tr><tr><td colspan="3">Reset Exit</td></tr></table>	93.2°C	9.0b	126.5°C	Reset Exit			5 Press the Encoder Knob to quit the submenu.
93.2°C	9.0b	126.5°C					
Reset Exit							
<table border="1"><tr><td>93.2°C</td><td>9.0b</td><td>126.5°C</td></tr><tr><td colspan="3">Exit Menu</td></tr></table>	93.2°C	9.0b	126.5°C	Exit Menu			6 You must scroll to the exit menu to exit the programming mode, or press the Encoder Knob for 2 seconds.
93.2°C	9.0b	126.5°C					
Exit Menu							

Water Quality

93.2°C	9.0b	126.5°C
Water Sensor Total Hardness:20 ppm TDS:140 ppm		

- This parameter allows the operator to view the TDS and water hardness values that are measured by the water probe at the inlet of the coffee machine.

Display	Operating Procedure
<div style="border: 1px solid black; padding: 2px; margin-bottom: 5px;"> 93.2°C 9.0b 126.5°C Password 0000 </div> <div style="border: 1px solid black; padding: 2px; margin-bottom: 5px;"> 93.2°C 9.0b 126.5°C Water Sensor Total Hardness:20 ppm TDS:140 ppm </div> <div style="border: 1px solid black; padding: 2px;"> 93.2°C 9.0b 126.5°C Exit Menu </div>	<ol style="list-style-type: none"> <li style="margin-bottom: 20px;"> 1 After entering the password and accessing the “Technician” programming menu, rotate the Encoder Knob until the following is displayed. <li style="margin-bottom: 20px;"> 2 Display of water hardness and TDS values. 3 You must scroll to the exit menu to exit the programming mode, or press the Encoder Knob for 2 seconds.

“Technical” Programming

Gateway

93.2°C	9.0b	126.5°C
Configure Gateway		

- This parameter allows the operator to connect the coffee machine to the WiFi connection.

Display	Operating Procedure						
<table border="1"> <tr> <td>93.2°C</td> <td>9.0b</td> <td>126.5°C</td> </tr> <tr> <td colspan="3" style="text-align: center;"> Password 0000 </td> </tr> </table>	93.2°C	9.0b	126.5°C	Password 0000			<ol style="list-style-type: none"> 1 After entering the password and accessing the “Technician” programming menu, rotate the Encoder Knob until the following is displayed. 2 Press the Encoder Knob to access the menu. 3 The Gateway is ready to connect to the WiFi network. Press the Encoder Knob to quit the submenu. 4 You must scroll to the exit menu to exit the programming mode, or press the Encoder Knob for 2 seconds.
93.2°C	9.0b	126.5°C					
Password 0000							
<table border="1"> <tr> <td>93.2°C</td> <td>9.0b</td> <td>126.5°C</td> </tr> <tr> <td colspan="3" style="text-align: center;"> Configure Gateway </td> </tr> </table>	93.2°C	9.0b	126.5°C	Configure Gateway			
93.2°C	9.0b	126.5°C					
Configure Gateway							
<table border="1"> <tr> <td>93.2°C</td> <td>9.0b</td> <td>126.5°C</td> </tr> <tr> <td colspan="3" style="text-align: center;"> Gateway Unlocked Press encoder to exit </td> </tr> </table>	93.2°C	9.0b	126.5°C	Gateway Unlocked Press encoder to exit			
93.2°C	9.0b	126.5°C					
Gateway Unlocked Press encoder to exit							
<table border="1"> <tr> <td>93.2°C</td> <td>9.0b</td> <td>126.5°C</td> </tr> <tr> <td colspan="3" style="text-align: center;"> Exit Menu </td> </tr> </table>	93.2°C	9.0b	126.5°C	Exit Menu			
93.2°C	9.0b	126.5°C					
Exit Menu							

Update Firmware

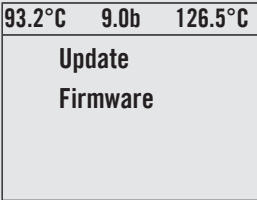

- This parameter allows the technician to update the control unit of the espresso machine via a USB Pendrive.

Display	Operating Procedure
<p>A screenshot of the espresso machine's LCD display. At the top, it shows three temperature readings: 93.2°C, 9.0b, and 126.5°C. Below these, the text 'Password 0000' is displayed.</p>	<p>1 After entering the password and accessing the “Technician” programming menu, rotate the Encoder Knob until the following is displayed.</p>
<p>A screenshot of the espresso machine's LCD display. At the top, it shows three temperature readings: 93.2°C, 9.0b, and 126.5°C. Below these, the text 'Update Firmware' is displayed.</p>	<p>2 Press the Encoder Knob to access the menu.</p>
<p>A screenshot of the espresso machine's LCD display. At the top, it shows three temperature readings: 93.2°C, 9.0b, and 126.5°C. Below these, the text 'Insert USB Key and Press Enter' is displayed.</p>	<p>3 Insert the USB Pendrive into the USB port and press the Encoder Knob.</p>
<p>A screenshot of the espresso machine's LCD display. At the top, it shows three temperature readings: 95.5°C, 8.7b, and 126.6°C. Below these, it shows '30.0g in 35s' and a progress bar. At the bottom, there is a scale from 0g to 60g and a timer showing 01/15.</p>	<p>4 When the update is over, the espresso machine restarts. Set the switch to 0 (zero) and then again to 1.</p>

“Technical” Programming

Exit Menu

93.2°C	9.0b	126.5°C
Exit Menu		

- This parameter allows the technician to exit the “Technical” programming and return to the normal use of the espresso machine.

Display	Operating Procedure						
<table border="1"><tr><td>93.2°C</td><td>9.0b</td><td>126.5°C</td></tr><tr><td colspan="3">Exit Menu</td></tr></table>	93.2°C	9.0b	126.5°C	Exit Menu			<ol style="list-style-type: none">1 Press the Encoder Knob to exit the “Technician” programming mode and return to the normal use of the espresso machine.
93.2°C	9.0b	126.5°C					
Exit Menu							

