

**La Marzocco Technical Bulletin #49 – June the 22<sup>nd</sup> 2011**  
**Strada EP new parts on paddle lever assembly**

We would like to inform you about the latest modifications of the Strada EP's Paddle lever.

The new paddle lever assembly is composed of improved parts, which makes it more robust and precise, also featuring a finer tuning of the maximum pressure by adjusting its stop position.

In addition, the bushing #05 is smaller in diameter for a more precise positioning of the rheostat when its replacement is needed.

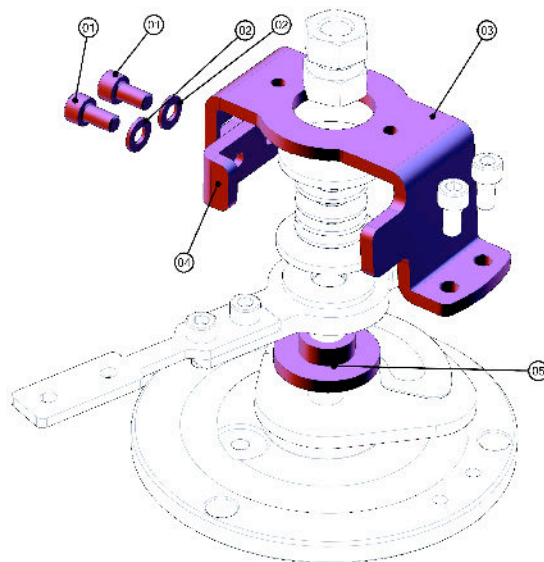

Please note that this change affects ALL units produced after machine serial number SN-EP0200.

A retrofit kit, code C.1.134.K, available FREE OF CHARGE from June the 20<sup>th</sup> 2011, will include the following parts:

- |     |                 |                                   |
|-----|-----------------|-----------------------------------|
| #01 | code I.1.005    | 2pc - 5x10 SOCKET HEAD S/S BOLT   |
| #02 | code I.1.039    | 2pc - S/S WASHER 5X10X1           |
| #03 | code C.1.123.01 | 1pc - BRACKET FOR EP              |
| #04 | code C.1.128    | 1pc - EP RHEOSTAT LEVER STOP      |
| #05 | code F.1.031    | 1pc - BUSHING FOR PADDLE EP LEVER |

Please do not hesitate to contact us if you need further clarification.

Sincerely yours,

After Sales Department

[enrico@lamarzocco.com](mailto:enrico@lamarzocco.com)  
[ettore@lamarzocco.com](mailto:ettore@lamarzocco.com)