

parts catalog vulcano swift

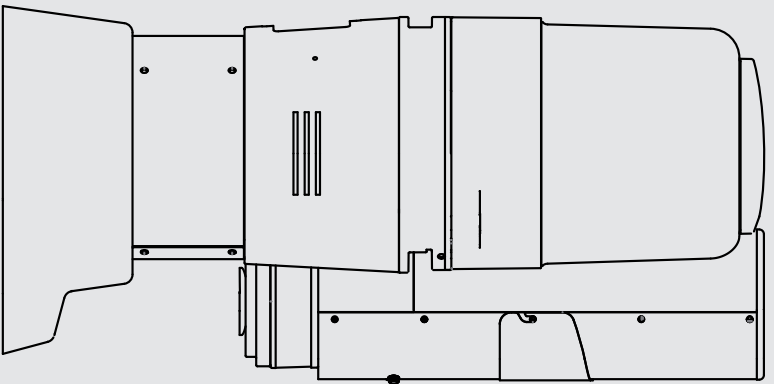

V1.3



la marzocco
handmade in florence





la marzocco
handmade in florence

INDEX

		Pag.	Ver.
Specifications	Caratteristiche Tecniche	4	1.3
Vulcano Swift Assembly	Vulcano Swift	6	1.3
Tower Section Assembly	Sezione Torre	14	1.3



la marzocco

handmade in florence

SPECIFICATIONS

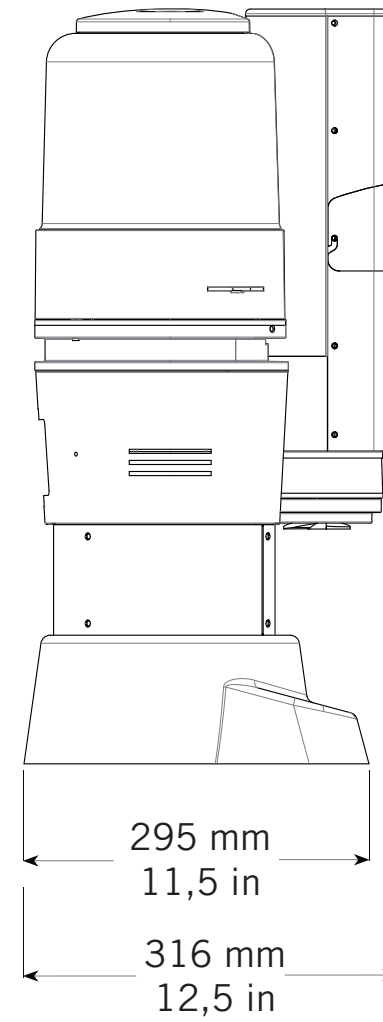
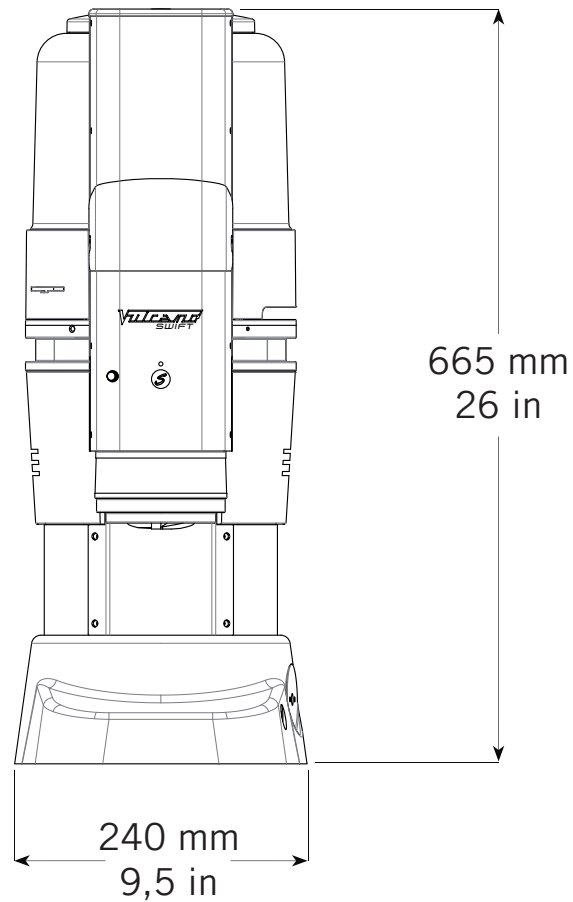



la marzocco
handmade in florence

SPECIFICATIONS

Caratteristiche Tecniche	Width	mm	240
		in	9,5
	Height	mm	665
		in	26
	Depth	mm	295
		in	11,5
	Machine weight	Kg	27
		lb	59,5
	Shipping weight	Kg	28,5
		lb	62,83
	Hopper	Kg	1,5
		lb	3,31
	Electrical Voltage	VAC	110VAC Single Phase
			220-240VAC Single Phase
380VAC Three Phase			
Total Wattage	W	500 Watts	
Grinding Cycle	On demand (time controlled)		
Grinder Burrs	Conical (Mazzer-made)		



la marzocco

handmade in florence

VULCANO SWIFT ASSEMBLY

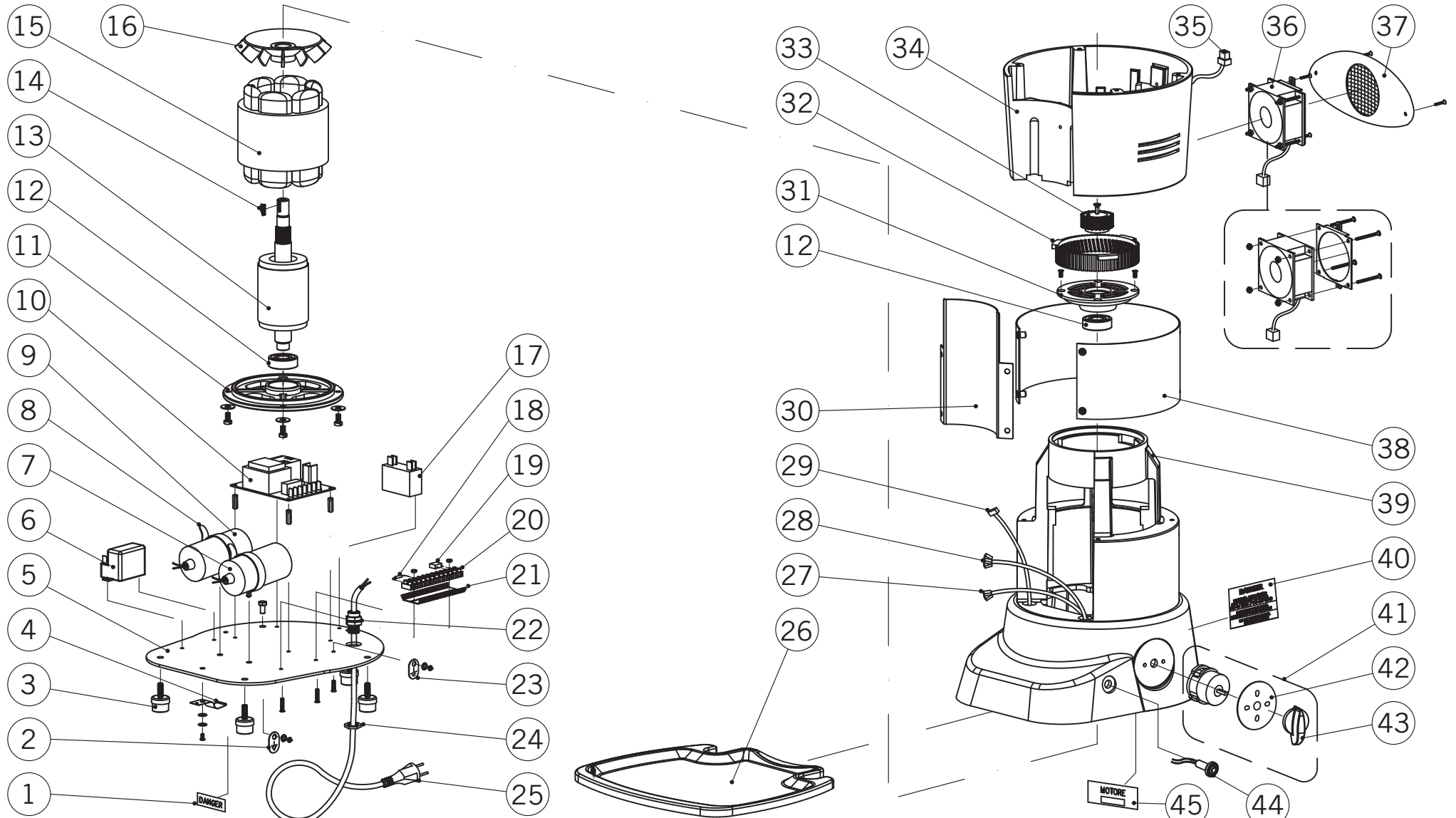



la marzocco

handmade in florence

VULCANO SWIFT ASSEMBLY

Vulcano Swift

1	M.1.037	"DANGER" LABEL	ETICHETTA "DANGER"	VERS. 110V/60HZ VERS. 220V/60HZ
2	M.1.094	"EXTERNAL EQUIPOTENTIAL CLAMP" PLATE	TARGA "MORSETTO EQUIPOTENZIALE ESTERNO"	VERS. CE
3	M.1.096	FOOT DD2015H	PIEDINO DD2015H	
4	M.1.093	SHEET FOR DRIP TRAY LOCKING	LAMELLA FERMA PIATTINO	
5	M.1.292	VULCANO SWIFT BOTTOM PLATE	PIASTRA DI BASE VULCANO SWIFT	
6	M.1.086	RELÈ "TEXAS" 4CR1-625	DISGIUNTORE "TEXAS" 4CR1-625	VERS. 220-230V/50HZ
	M.1.087	RELÈ "TEXAS" 4CR1-630	DISGIUNTORE "TEXAS" 4CR1-630	VERS. 230-240V/50HZ VERS. 240V/50HZ
	M.1.088	RELÈ "TEXAS" 4CR1-640	DISGIUNTORE "TEXAS" 4CR1-640	VERS. 220V/60HZ
	M.1.090	RELÈ "TEXAS" 4CR1-690	DISGIUNTORE "TEXAS" 4CR1-690	VERS. 110V/60HZ VERS. 110V/50HZ
7	M.1.116	CAPACITOR 10 μ F	CONDENSATORE 10 μ F	VERS. 220V/60Hz VERS. 220-230V/50Hz VERS. 230-240V/50Hz VERS. 240V/50Hz
	M.1.117	CAPACITOR 30 μ F UL	CONDENSATORE 30 μ F UL	VERS. 110V/60Hz
8	M.1.278	STRAP RELF 170 BLACK	FASCETTA SBLOCCABILE RELF 170 NERA	
9	M.1.114	CAPACITOR 12,5 μ F	CONDENSATORE 12,5 μ F	VERS. 220V/60HZ VERS. 220-230V/50HZ VERS. 230-240V/50HZ VERS. 240V/50HZ
	M.1.115	CAPACITOR 40 μ F UL	CONDENSATORE 40 μ F UL	VERS. 110V/60HZ
10	M.1.290	VULCANO SWIFT POWER BOARD 220-240-50-60	SCHEDA POT. VULCANO SWIFT 220-240/50-60	220V/60HZ 220-230V/50HZ 230-240V/50HZ 240V/50HZ
	M.1.291	VULCANO SWIFT POWER BOARD 100-115/50-60	SCHEDA POT. VULCANO SWIFT 100-115/50-60	VERS. 110V/60HZ
11	M.1.277	SUPER JOLLY – KONY MOTOR CAP	CALOTTA MOTORE SUPER JOLLY – KONY	
12	M.1.018	BEARING 6202 DDU CM	CUSCINETTO 6202 DDU CM	
13	M.1.081	KONY ROTOR	ROTORE KONY	
14	M.1.074	KEY 4X4X14 UNI 6604 A	CHIAVETTA 4X4X14 UNI 6604 A	
Item	Part number/Codice	Description	Descrizione	Notes / Note



la marzocco

handmade in florence

VULCANO SWIFT ASSEMBLY

Vulcano Swift

15	M.1.274	COILED STATOR SINGLE PHASE 220-240V/50HZ	STATORE AVVOLTO MONOFASE 220-240V/50HZ	VERS. 220-230V/50HZ VERS. 230-240V/50HZ VERS. 240V/50HZ
	M.1.275	COILED STATOR SINGLE PHASE 110V/60HZ	STATORE AVVOLTO MONOFASE 110V/60HZ	VERS. 110V/60Hz
	M.1.276	COILED STATOR SINGLE PHASE 220V/60HZ	STATORE AVVOLTO MONOFASE 220V/60HZ	VERS. 220V/60HZ
16	M.1.289	KONY COOLING FAN	VENTOLA KONY	
17	E.2.043	CAPACITOR 2,5 μ F	CONDENSATORE 2,5 μ F	VERS. 220V/60Hz VERS. 220-230V/50Hz VERS. 230-240V/50Hz VERS. 240V/50Hz
	E.2.044	CAPACITOR 8 μ F	CONDENSATORE 8 μ F	VERS. 110V/60Hz
18	M.1.111	LOAD RESISTOR 220 KILO-OHM 2 WATT	RESISTENZA 220 KILO-OHM 2 WATT	VERS. 220V/60Hz VERS. 220-230V/50Hz VERS. 230-240V/50Hz VERS. 240V/50Hz
	M.1.112	LOAD RESISTOR 68 KILO-OHM 2 WATT	RESISTENZA 68 KILO-OHM 2 WATT	VERS. 110V/60Hz
19	M.1.110	INTERFERENCE SUPPRESSION CAPACITOR	CONDENSATORE ANTIDISTURBI	VERS. 220V/60Hz VERS. 220-230V/50Hz VERS. 230-240V/50Hz VERS. 240V/50Hz
20	M.1.108	TERMINAL BLOCKS	MORSETTIERA	12 POLES / 12 POLI
21	M.1.109	UNDER TERMINAL BOARD	SOTTOMORSETTIERA	12 POLES / 12 POLI
22	M.1.113	CABLE LOCKING NSK-K PG11 BLACK	PASSACAVO NSK-K PG11 NERO	
23	M.1.107	"GROUND" PLATE	TARGA "TERRA"	
24	M.1.095	NUT FOR CABLE LOCKING PG11	DADO POLIAMMIDE PG11 NERO	
25	M.1.098	ELECTRICAL CABLE – ITALY	CAVO ELETTRICO - ITALIA	
	M.1.098	ELECTRICAL CABLE – EUROPE	CAVO ELETTRICO - EUROPA	
	M.1.099	ELECTRICAL CABLE – USA	CAVO ELETTRICO - AMERICA	
Item	Part number/Codice	Description	Descrizione	Notes / Note



la marzocco

handmade in florence

VULCANO SWIFT ASSEMBLY

Vulcano Swift

25	M.1.100	ELECTRICAL CABLE – AUSTRALIA	CAVO ELETTRICO - AUSTRALIA	
	M.1.101	ELECTRICAL CABLE – GREAT BRITAIN	CAVO ELETTRICO - GRAN BRETAGNA	
	M.1.102	ELECTRICAL CABLE – ISRAEL	CAVO ELETTRICO - ISRAELE	
	M.1.103	ELECTRICAL CABLE – SWITZERLAND	CAVO ELETTRICO - SVIZZERA	
	M.1.104	ELECTRICAL CABLE – CHINA	CAVO ELETTRICO - CINA	
	M.1.105	ELECTRICAL CABLE – ARGENTINA	CAVO ELETTRICO - ARGENTINA	
	M.1.106	ELECTRICAL CABLE – KOREA	CAVO ELETTRICO - COREA	
	M.1.293	ELECTRICAL CABLE – BRAZIL	CAVO ELETTRICO - BRASILE	
26	M.1.059	S.JOLLY-MAJOR-KONY DRIP TRAY	PIATTINO S.JOLLY-MAJOR-KONY	
27	M.1.287	CONNECTION CABLE FOR FILTER SWITCH	CAVO CONNESSIONE MICRO PRESENZA COPPA	
28	M.1.286	CONNECTION CABLE FOR TAMPER MOTOR	CAVO CONNESSIONE MOTORE TORRE	
29	M.1.285	CONNECTION CABLE FOR PUSH BUTTON BOARD	CAVO CONNESSIONE SCHEDA PULSANTE	
30	M.1.271	MOTOR COVER FOR VULCANO SWIFT	FRONTALE COPRI MOTORE VULCANO SWIFT	
31	M.1.213	BEARING HOLDER-DISK KONY	DISCO PORTACUSCINETTO KONY	
32	M.1.212	REDUCTION CROWN	CORONA RIDUZIONE PLANETARIA	
33	M.1.051	REDUCTION PLANET	PIANETA RIDUZIONE PLANETARIA	
34	M.1.270	BODY FOR VULCANO SWIFT	CORPO CORPO VULCANO SWIFT	
35	M.1.028	CONNECTION CABLE FOR FAN (AUT)	CAVO CONNESSIONE VENTOLA (AUT)	
36	M.1.029	FAN 60X60 – WIRED WITH FRAME	VENTILATORE 60X60 CABLATO CON SUPPORTO	
37	D.4.003	FILTER FOR VULCANO ON DEMAND	FILTRO VENTOLA VULCANO	
38	M.1.272	COVER FOR VULCANO SWIFT	MANTELLINO VULCANO SWIFT	
39	M.1.273	VULCANO SWIFT BASE AND INNER BODY	ASSIEME CASTELLO VULCANO SWIFT	
40	M.1.037	“DANGER” PLATE	TARGA “DANGER”	VERS. 110V/60Hz
Item	Part number/Codice	Description	Descrizione	Notes / Note



la marzocco

handmade in florence

VULCANO SWIFT ASSEMBLY

Vulcano Swift	41	M.1.224	TWO POLE ROTATIVE SWITCH	INTERRUTTORE ROTATIVO BIPOLARE	SINGLE PHASE / MONOFASE
		M.1.225	THREE POLE ROTATIVE SWITCH	INTERRUTTORE ROTATIVO TRIPOLARE	THREE PHASE / TRIFASE
	42	M.1.288	SWITCH PLATE O / I	TARGA INTERRUTTORE O / I	
	43	M.1.066	ROTATIVE SWITCH KNOB	MANOPOLINA INTERRUTTORE	
	44	M.1.067	PILOT LIGHT 230/400V, GREEN	LAMPADINA SPIA 230/400V, VERDE	VERS. 220V/60HZ VERS. 220-230V/50HZ VERS. 230-240V/50HZ VERS. 240V/50HZ
		M.1.070	PILOT LIGHT 110V UL, RED	LAMPADINA SPIA 110V UL, ROSSA	VERS. 110V/60HZ
	45		MOTOR LABEL	ETICHETTA MOTORE	
	Item	Part number/Codice	Description	Descrizione	Notes / Note



la marzocco

handmade in florence

VULCANO SWIFT ASSEMBLY

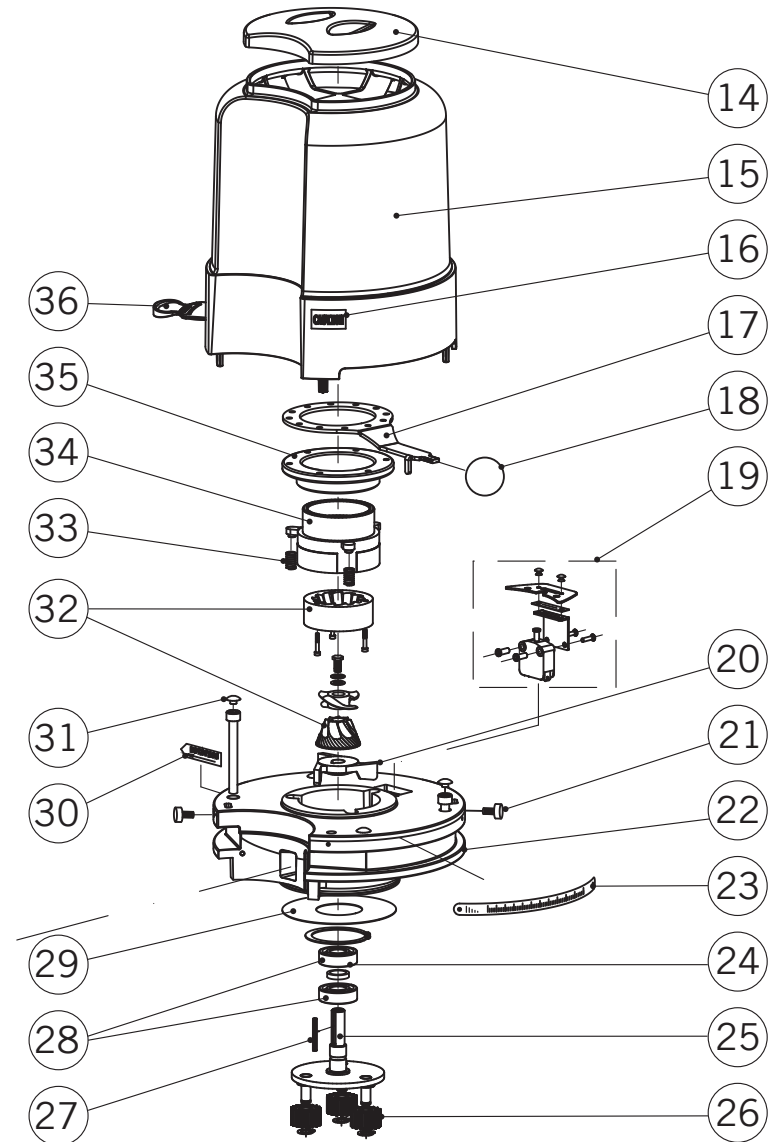
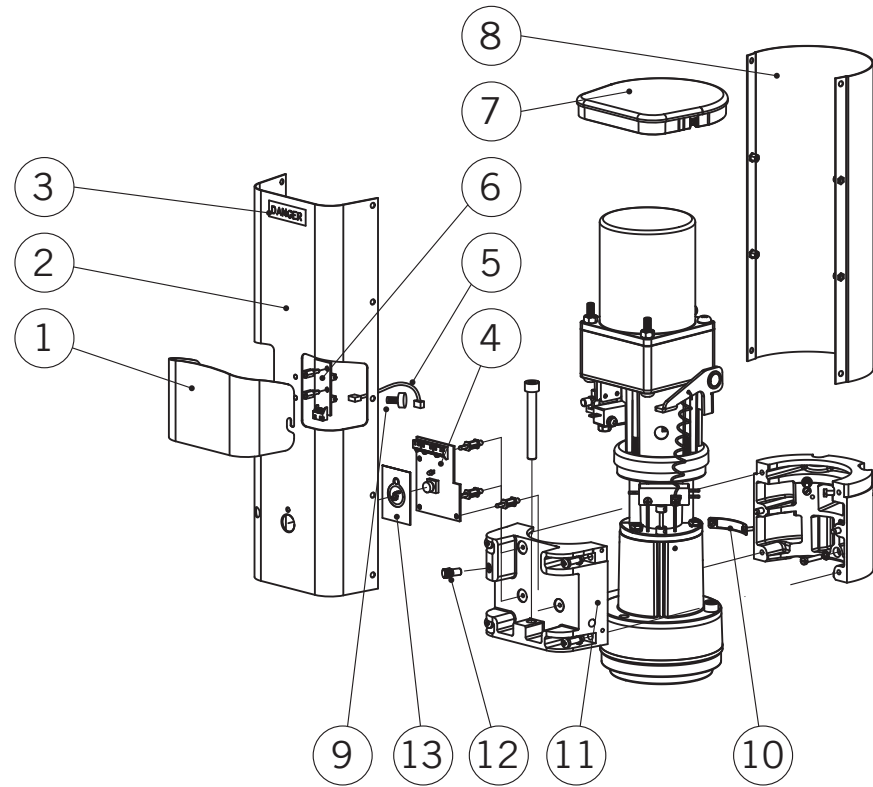



la marzocco

handmade in florence

VULCANO SWIFT ASSEMBLY

Vulcano Swift

1	C.1.350	FRONT TOWER W/LOGO	FRONTALE TORRE C/LOGO	
2	M.1.280	TOWER FRONT COVER	COPERTURA FRONTALE TORRE PRESSANTE	
3	M.1.037	"DANGER" LABEL	ETICHETTA "DANGER"	VERS. 110V/60HZ VERS. 220V/60HZ
4	M.1.296	PUSH BUTTON BOARD	SCHEDA PULSANTE	
5	M.1.295	CONNECTION CABLE FOR TRIMMERS BOARD	CAVO CONNESSIONE SCHEDA TRIMMER	
6	M.1.294	TRIMMERS BOARD	SCHEDA TRIMMER	
7	M.1.279	TOWER LID	COPERCHIO TORRE PRESSANTE	
8	M.1.282	TOWER BACK COVER	COPERTURA POSTERIORE TORRE PRESSANTE	
9	I.3.012	SCREW M4X10 PHIL.ROUND-PAN GALV.	VITE 4X10 TCB ZINCATO	
10	M.1.299	VULCANO SWIFT GRID	RETINA PASSAGGIO CAFFÈ VULCANO SWIFT	
11	M.1.284	EXTERNAL JAW	GANASCIA ESTERNA	
12	M.1.298	PLUG HOLE FOR COFFEE OUTLET CLEANING	TAPPO FORO PULIZIA BOCCHETTA	
13	M.1.297	ADHESIVE MEMBRANE VULCANO SWIFT	MEMBRANA PULSANTE VULCANO SWIFT	
14	M.1.267	VULCANO SWIFT HOPPER COVER	COPERCHIO CAMPANA VULCANO SWIFT	
15	M.1.268	COMPLETE VULCANO SWIFT HOPPER SET	ASSIEME CAMPANA VULCANO SWIFT	
16	M.1.083	"CAUTION-HOPPER" LABEL	ETICHETTA "CAUTION-HOPPER"	VERS. 110V/60HZ VERS. 220V/60HZ
17	M.1.007	ADJUSTMENT LEVER FOR VULCANO	LEVA DI REGOLAZIONE VULCANO	
18	M.1.006	BALL GRIP FOR ADJUSTMENT LEVER	POMOLO LEVA DI REGOLAZIONE	
19	M.1.021	SAFETY MICROSWITCH	MICROINTERRUTTORE DI SICUREZZA CAMPANAV	
20	M.1.013	LOWER GRINDING BLADE HOLDER KONY SINGLE PHASE	PORTAMACINE INFERIORE KONY MONOFASE	SINGLE PHASE / MONOFASE
	M.1.205	LOWER GRINDING BLADE HOLDER KONY 3 PHASE	PORTAMACINE INFERIORE KONY TRIFASE	THREE PHASE / TRIFASE
21	M.1.022	CHECK PIN FOR HOPPER FOR VULCANO	PERNO BLOCCA CAMPANA VULCANO	
22	M.1.269	VULCANO SWIFT BODY-HEAD	TESTA VULCANO SWIFT	
23	M.1.024	GRINDING ADJUSTMENT INDICATOR	INDICE REGOLAZIONE MACINATURA VULCANO	
Item	Part number/Codice	Description	Descrizione	Notes / Note



la marzocco

handmade in florence

VULCANO SWIFT ASSEMBLY

Vulcano Swift

24	M.1.019	THICKNESS PLANETARY SHAFT	SPESSORE ALBERO RIDUZIONE PLANETARIA	
25	M.1.026	SHAFT WITH 3 PIVOTS FOR SIGLE PHASE KONY	ALBERO CON 3 PERNI KONY MONOFASE	
	M.1.209	SHAFT WITH 3 PIVOTS FOR 3 PHASE KONY	ALBERO CON 3 PERNI KONY MONOFASE	
26	M.1.027	REDUCTION SATELLITE	SATELLITE RIDUZIONE PLANETARIA	
27	M.1.020	KEY 3X3X30 UNI 6604 A	CHIAVETTA 3X3X30 UNI 6604 A	
28	M.1.018	BEARING 6202 DDU CM	CUSCINETTO 6202 DDU CM	
29	M.1.017	DISC TO CLOSE KONY BODY-HEAD	DISCO CHIUSURA TESTA KONY	
30	M.1.015	"MOTOR ROTATION" LABEL	ETICHETTA "ROTAZIONE MOTORE"	
31	M.1.014	CAP FOR TCE M6 SCREWS	CAPPUCCIO VITI TCE M6	
32	M.1.011	CONICAL GRINDING BLADE SET 191C	COPPIA DI MACINE CONICHE(RIF. 191C)	SINGLE PHASE / MONOFASE
	M.1.202	CONICAL GRINDING BLADE SET 191C	COPPIA DI MACINE CONICHE(RIF. 191C)	THREE PHASE / TRIFASE
33	M.1.300	GRINDING ADJUSTMENT SPRING	MOLLA REGOLAZIONE MACINATURA	
34	M.1.009	UPPER GRINDING BLADE HOLDER KONY SINGLE PHASE	PORTAMACINE SUPERIORE KONY MONOFASE	SINGLE PHASE / MONOFASE
	M.1.201	UPPER GRINDING BLADE HOLDER KONY 3 PHASE	PORTAMACINE SUPERIORE KONY TRIFASE	THREE PHASE / TRIFASE
35	M.1.008	VULCANO COFFEE GRINDING ADJUSTMENT DISK	GHIERA REGOLAZIONE VULCANO	
36	M.1.005	VULCANO LOCKING SLIDE	SERRANDA VULCANO	
Item	Part number/Codice	Description	Descrizione	Notes / Note



la marzocco

handmade in florence

TOWER SECTION ASSEMBLY

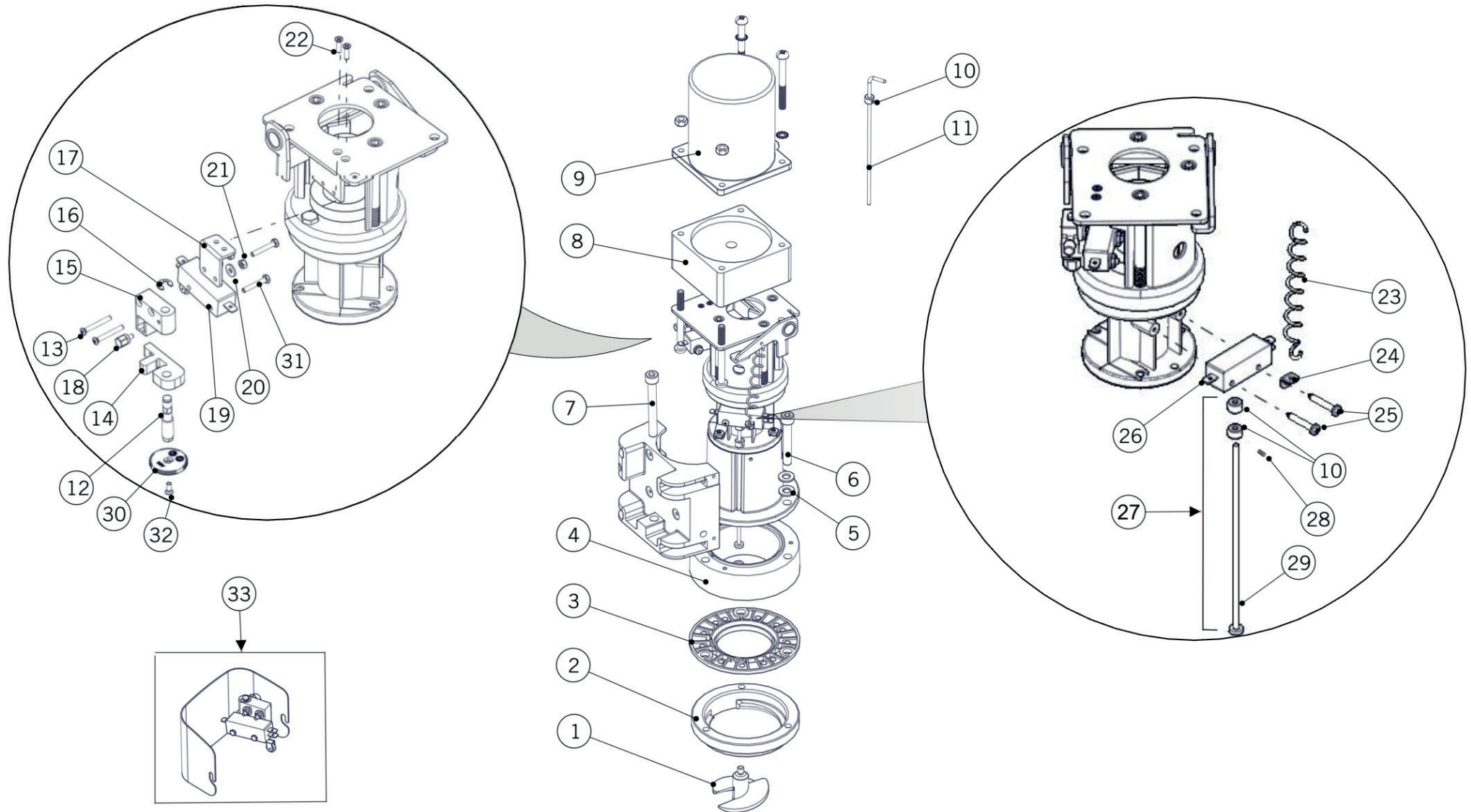



la marzocco

handmade in florence

TOWER SECTION ASSEMBLY

Sezione Torre

1	5.331.01	TAMPER IMPELLER	ELICA PRESSANTE	
2	L109.01	BAYONET RING	ANELLO CROMATO	
3	5.353	PORTAFILTER SPACER	DISTANZIALE PORTAFILTRO	
4	5.354	COFFEE CHUTE SPACER	CONVOGLIATORE CAFFE'	
5	L1003	WASHER 8,5X14X1,5 S/S A2	RONDELLA 8,5X14X1,5 INOX A2	
6	L110.01	SCREW M8X52 SOCKET CAP S/S A2	VITE M8X52 TC A BRUGOLA INOX A2	
7	I.1.072	SCREW M8X70 SOCKET CAP S/S A2	VITE M8X70 TC A BRUGOLA INOX A2	
8	5.300.R	REDUCTION GEAR MOTOR 230V 50/60HZ S/D	RIDUTTORE MOTORE 230V 50/60HZ S/D	
9	5.300	230V 50/60HZ SWIFT TAMPER MOTOR	MOTORE 230V/ 50/60HZ X DOSATURA SWIFT	
	5.300/110	115V 50/60HZ SWIFT TAMPER MOTOR	MOTORE 115V 50/60HZ X DOSATURA SWIFT	
10	5.372.3.01	COLLAR D9.3 GALVANIZED SWIFT TOWER	COLLARE D9.3 ZINCATO TORRE SWIFT	
11	5.372.5	CLEAN OUT TOOL	UTENSILE PER PULIZIA	
12	I.2.004	SCREW REGULATION MICROSWITCH	VITE REGOLAZIONE MICROSWITCH	
13	5.V018	#6-32 X 1-1/4 S/S PAN HEAD PHILLIPS M/S	VITE A TAGLIO INOX #6-32 X 1-1/4	
14	F.6.010	BRACKET MOVABLE MICROSWITCH	STAFFA MOBILE MICROSWITCH	
15	F.6.009	BRACKET FIXING REGULATION MICROSWITCH	STAFFA FISSAGGIO REGOLAZIONE MICROSWITCH	
16	I.1.071	SEEGER RING D5MM UNI 7434	SEEGER D5 ACCIAIO FOSFATO NERO UNI 7434	
17	C.1.169	BRACKET FOR MICRO REGULATING SYSTEM	STAFFA SISTEMA REGOLAZIONE MICRO	
18	I.1.095	SCREW BLOCKING MICROSWITCH	VITE BLOCCAGGIO MICROSWITCH	
19	5.117	ROLLER SWITCH W/LEVER	MICROINTERRUPTORE CON LEVETTA	
20	I.3.007	TOOTH LOCK WASHER 3,4X6X0,5 GALVANIZED	ROND.DENTATA 3,4X6X0,5 ZINCATA	
21	DADOINOXM3	NUT M3 H2 WR5,5 S/S A2	DADO M3 H2 CH5,5 INOX A2	
22	I.1.045	SCREW M3X12 PHILLIPS COUNTERSUNK S/S A2	VITE M3X12 TS A CROCE INOX A2	
23	F.3.037	MOTOR LOCK SPRING FOR VULCANO SWIFT	MOLLA PER FERMO MOTORE VULCANO SWIFT	
24	C.1.167	BRAKE SPRING BRACKET	STAFFA MOLLA FRENO	
25	5.V016	#6 X7/8 PAN HEAD PHILLIPS	VITE A CROCE #6X7/8	
26	5.117.1	PIN SWITCH WITHOUT LEVER	PIN SWITCH SENZA LEVETTA	
27	5.372.01	ASSEMBLY ROD PORTAFILTER PRESENCE SWIFT	ASSIEME ASTA PRESENZA PORTAFILTRO SWIFT	
28	5.372.2	GRUB SCREW UNC 6-32X3 S/S	GRANO INOX UNC 6-32X3	
29	5.372.1.01	ROD PORTAFILTER PRESENCE SWIFT TOWER	ASTA PRESENZA PORTAFILTRO TORRE SWIFT	
30	F.1.091	ADJUSTMENT KNOB SWITCH	GHIERA REGOLAZIONE SWITCH	
31	I.1.055	SCREW M3X20 HEX HEAD S/S A2	VITE M3X20 TE INOX A2	
32	I.1.004	SCREW M3X8 SOCKET COUNTERSUNK S/S A2	VITE M3X8 TS A BRUGOLA INOX A2	
33	904	ADJUSTMENT KIT VULCANO SWIFT	KIT REGOLAZIONE VULCANO SWIFT	
Item	Part number/Codice	Description	Descrizione	Notes / Note



la marzocco

handmade in florence

TOWER SECTION ASSEMBLY

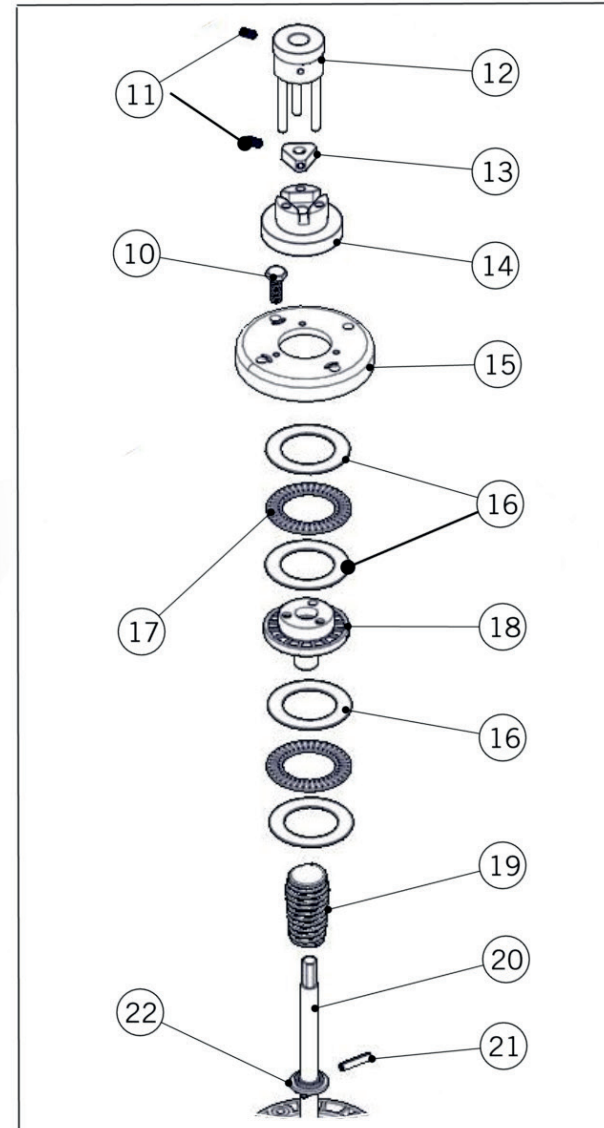
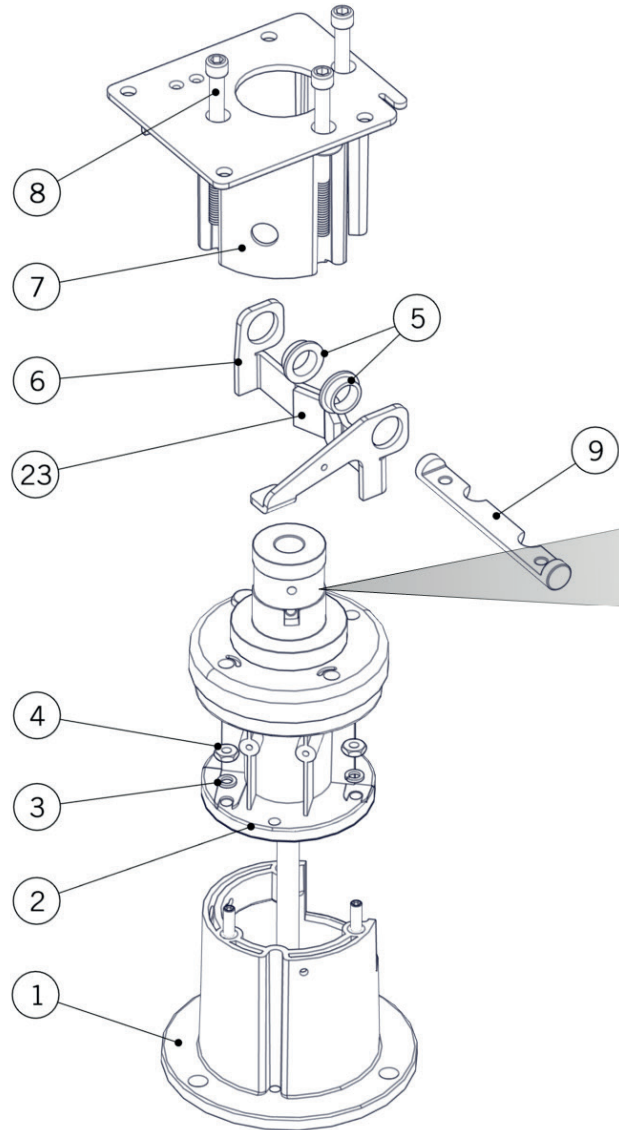



la marzocco

handmade in florence

TOWER SECTION ASSEMBLY

Sezione Torre

1	5.377	COFFEE CHUTE MODIFIED FOR VULCANO SWIFT	CANALE CAFFE' MODIFICATO VULCANO SWIFT	
2	5.358	THRUST BEARING RETAINER. PLAST	SUPPORTO CUSCINETTO	
3	5.V003	#10 EXTERNAL TOOTH LOCK WASHER	RONDELLA DENTATA #10	
4	5.V005	S/S #10-32 UNF HEX NUT	DADO INOX #10-32 UNF	
5	F.1.038	BUSHING FOR BRAKE LEVER	BOCCOLA PER LEVA FRENO	
6	C.1.168	BRAKE LEVER	LEVA FRENO	
7	5.379	MOTOR MOUNT MODIFIED FOR VULCANO SWIFT	SUPPORTO MOTORE MODIFICATO VULCANO SWIFT	
8	5.V022	1/4-20 UNC X 3-1/4 SOCKET HEAD ALLEN	VITE A BRUGOLA 1/4-20 UNC X 3-1/4	
9	5.370.01	SHAFT LOCK MOUNT VULCANO SWIFT	ALBERO BLOCCAGGIO MOTORE	
10	5.V015	1/4-20 UNC x 5/8 HEX HEAD SCREW	VITE ESAGONALE 1/4-20 UNC x 5/8	
11	5.V014	S/S #10-32 x 3/8 SOCKET SET SCREW	GRANO DI BLOCCAGGIO #10-32 x 3/8	
12	5.130	MOTOR SHAFT COUPLING	ACCOPIAMENTO ALBERO MOTORE	
13	5.131	TAMPER SHAFT COLLAR	ANELLO PER ALBERO ELICA PRESSANTE	
14	5.132	TAMPER SHAFT COUPLING	ACCOPIAMENTO ALBERO ELICA PRESSANTE	
15	5.355	THRUST BEARING RETAINER TOP	ANELLO SUPPORTO CUSCINETTO	
16	5.106	THRUST BEARING WASHER	DISTANZIALE PER CUSCINETTO	
17	5.105	THRUST BEARING	CUSCINETTO	
18	5.360	BEARING SPINDLE	GUIDA CUSCINETTO	
19	5.111	SPRING 1,3X25,4X86,5 VARIABLE DIAMETER	MOLLA 1,3X25,4X86,5 DIAMETRO VARIABILE	
20	5.328.01	TAMPER SHAFT (ASSEMBLED WITH 5.109)	ALBERO ELICA PRESSANTE (C/5.109)	
21	5.109	ROLL PIN 3/16 x 7/8 420SS	SPINA ELASTICA 3/16 X 7/8 420SS	
22	5.359	SPRING RETAINER	SUPPORTO PER MOLLA	
23	5.343.2	SWIFT FOOT RUBBER	FRENO IN GOMMA	
Item	Part number/Codice	Description	Descrizione	Notes / Note

LA MARZOCCO SRL
Via La Torre, 14/H
Localita' La Torre
50038 Scarperia e San Piero
(Florence) - ITALY
T. +39 055 849 191
F. +39 055 849 1990
info@lamarzocco.com
www.lamarzocco.com