

# parts catalog swift eps<sub>h</sub>

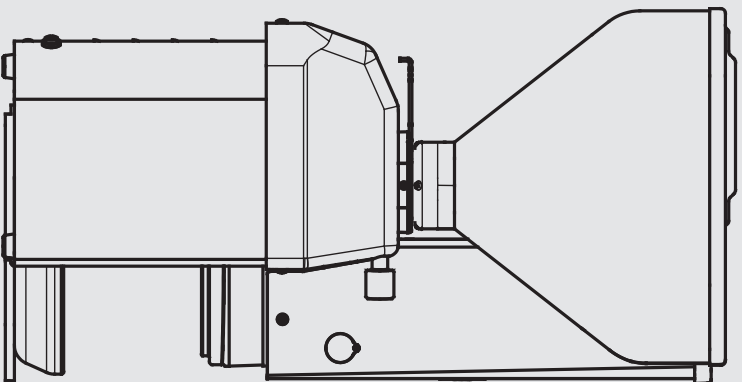





**la marzocco**  
handmade in florence

## INDEX

		Pag.	Vers.
Specifications	Caratteristiche Tecniche	4	2.4
Swift EPS	Swift EPS	6	2.4
Tower Section	Esploso torre	8	2.4
Grinder and Accessories	Grinder e Accessori	10	2.4



**la marzocco**  
handmade in florence

## SPECIFICATIONS

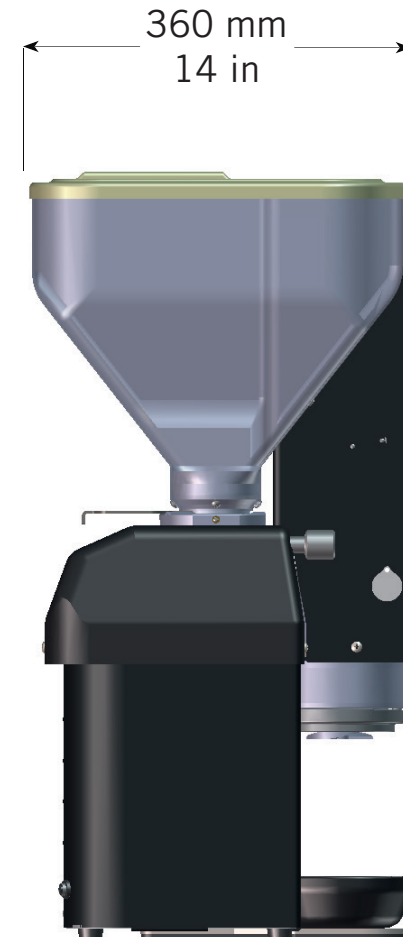



**la marzocco**  
handmade in florence

# SPECIFICATIONS

<b>Caratteristiche Tecniche</b>	Width	mm	350
		in	13,78
	Height	mm	655
		in	25,78
	Depth	mm	360
		in	14
	Machine weight	Kg	31
		lb	68
	Shipping weight	Kg	32,5
		lb	71,65
	Hopper	Kg	1,8 x 2
		lb	4 x 2
	Electrical Voltage	VAC	110VAC Single Phase
			220VAC Single Phase
Total Wattage	W	780 Watts	
Operation Type	Automatic		
Burr Type	Ceramic Flat		



la marzocco

handmade in florence

# SWIFT EPS ASSEMBLY

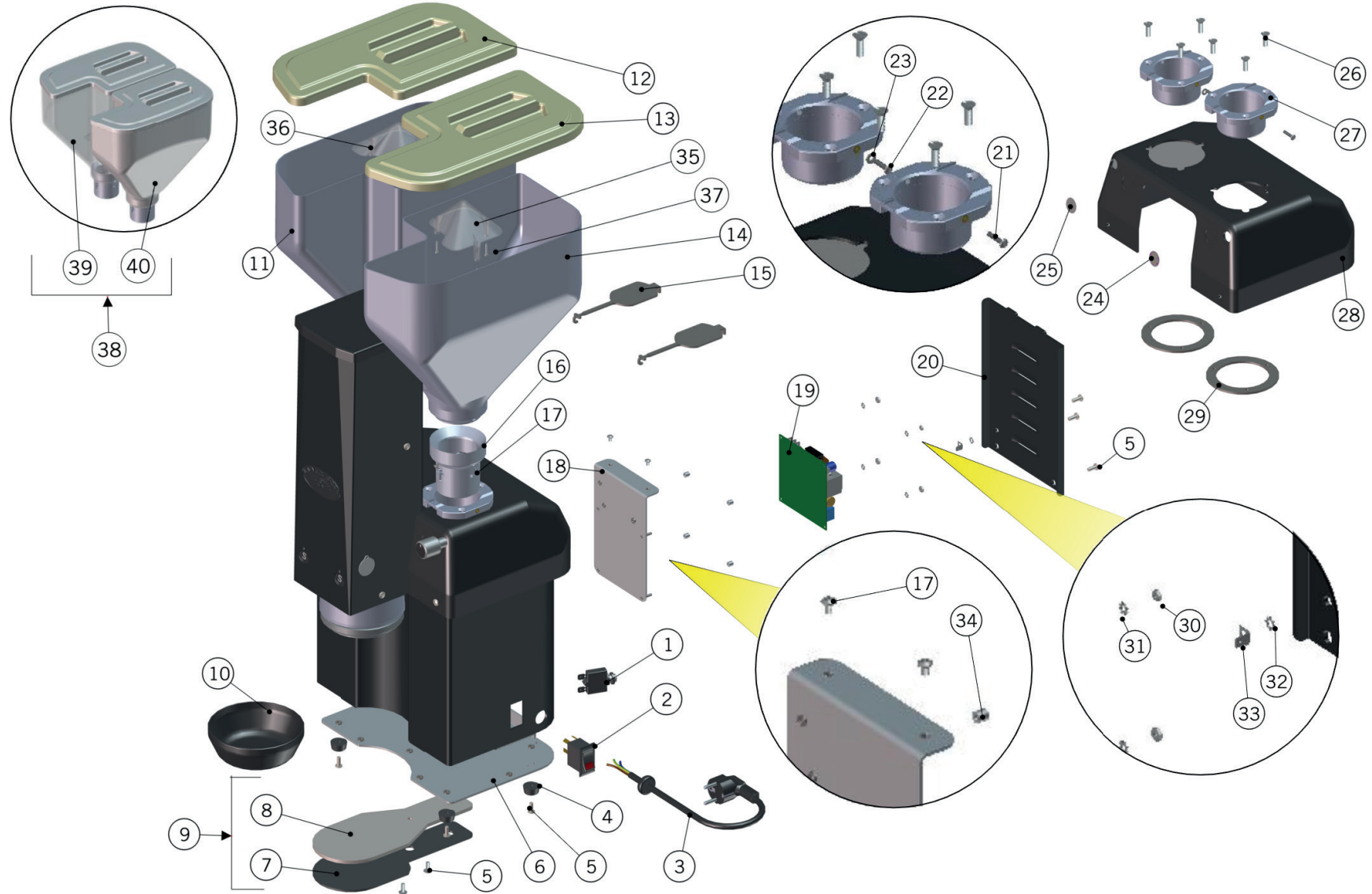



**la marzocco**

handmade in florence

# SWIFT EPS ASSEMBLY

**Swift Eps**

1	5.373	RESETTABLE BREAKER 10A	20	5.309	BACK COVER ALUMINUM
2	5.116	ON/OFF SWITCH W/LIGHT	21	5.V024	#8-32 X 3/4 PAN HEAD SLOTTED
3	5.114	POWER CORD W/STRAIN RELIEF	22	5.V023	#8-32 UNF X 5/8 PAN HEAD
	5.506	SWIFT POWER CORD FOR AUS	23	5.V025	#8 SPLIT RING LOCK WASHER S/S
	5.136	POWER CORD EURO 14/3	24	5.339.1	CLOCKWISE SLOW POUR DECAL
4	5.120	FOOT. 3/4 DIA RUBBER	25	5.339.2	CTRCLOCKWISE SLOW POUR DECAL
5	5.V001	#10-32 UNF X 1/2 TRUSS HEAD	26	5.V021	1/4"-20 UNC X 3/4 FLAT HEAD
6	5.306	BOTTOM PLATE	27	5.361	HOPPER SLEEVE
7	5.343	SWIFT FOOT RUBBER	28	5.368	GRINDER COVER W/FRONT KNOBS
8	5.342	SWIFT FOOT PLATE	29	5.313	BOLT RINGS
9	5.341.1	FOOT PLATE ASSY (5.342+5.343)	30	5.V009	S/S #6-32 UNF HEX NUTS
10	5.336	DRIP TRAY	31	5.V008	#6 EXTERNAL TOOTH LOCK WASHER
11	5.333.02	HOPPER LEFT	32	5.V003	#10 EXTERNAL TOOTH LOCK WASHER
12	5.369.01	HOPPER LID LEFT NSF PLASTIC	33	5.V004	FASTON 1/4" NON INSULATED
13	5.367.01	HOPPER LID RIGHT NSF PLASTIC	34	5.376	#6-32UNF X1/4 X 1/4 ROUND
14	5.332.02	HOPPER RIGHT	35	5.381	PROTECTION HOPPER RIGHT
15	5.315	BEAN GATE	36	5.383	PROTECTION HOPPER LEFT
16	5.319.01	HOPPER MOUNT	37	1.1.094	SELFTAP.SCREW 2,9X16 PHIL ROUND-PAN S/S
17	5.V013	#8-32 UNF X1/4" PAN HEAD	38	937	UPDATE KIT NEW SWIFT HOPPERS
18	5.310	TRANSFORMER MOUNT SS	39	5.333.R	HOPPER LEFT
19	5.305.1/11	TRANSFORMER BOARD. TYPE G 110V	40	5.332.R	HOPPER RIGHT
	5.305.1/22	TRANSFORMER BOARD. TYPE G 220V			
<b>Item</b>	<b>Part number/Codice</b>	<b>Description</b>	<b>Item</b>	<b>Part number/Codice</b>	<b>Description</b>



la marzocco  
handmade in florence

# TOWER SECTION ASSEMBLY

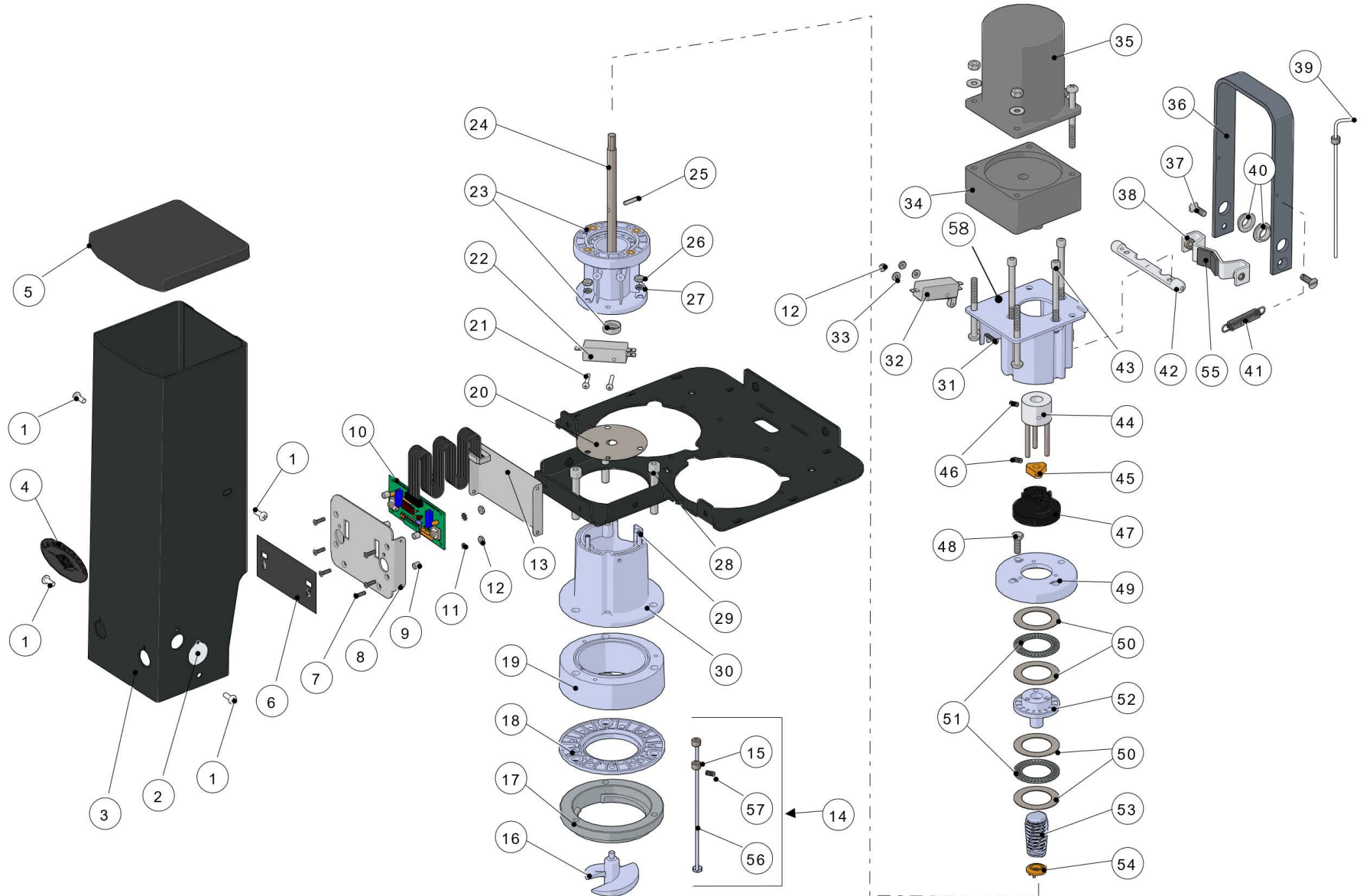





**la marzocco**

handmade in florence

# TOWER SECTION ASSEMBLY

**Sezione Torre**

1	5.V001	#10-32 UNF X 1/2 TRUSS HEAD	30	5.356	COFFEE CHUTE
2	5.314	MEDAL SWIFT TOWER	31	5.V018	#6-32 X 1-1/4 S/S PAN HEAD PHILLIPS M/S
3	5.311	TAMPER COVER ALUMINUM	32	5.117	ROLLER SWITCH W/LEVER
4	5.340	DECAL. OVAL. LM LOGO	33	5.V020	S/S #6 FLAT WASHER
5	5.337	TAMPER COVER LID	34	5.300.R	REDUCTION GEAR MOTOR 230V 50/60HZ S/D
6	D.5.031	SWIFT BUTTON COVER OVERLAY PE	35	5.300/110	230V 50/60HZ SWIFT TAMPER MOTOR
7	5.V012	#6-32 UNF X 1/2 FLAT HEAD		5.300	115V 50/60HZ SWIFT TAMPER MOTOR
8	5.312	ELECTRONICS MOUNT PLATE	36	5.347	SHAFT LOCK LEVER
9	5.376	#6-32UNF X1/4 X 1/4 ROUND	37	5.V021	1/4"-20 UNC X 3/4 FLAT HEAD
10	5.304.1	CONTROL. 2 BUTTON. TYPE G	38	5.348.C	SHAFT LOCK SHOE ASSEMBLED
	5.304.2	CONTROL. 2 BUTTON. TYPE G *	39	5.372.5	CLEAN OUT TOOL
11	5.V008	#6 EXTERNAL TOOTH LOCK WASHER	40	5.345	BEARING PLAIN FLANGED
12	5.V009	S/S #6-32 UNF HEX NUTS	41	5.122	SPRING FY
13	5.316	ELECTRONIC MOUNT PLATE COVER	42	5.370	SHAFT LOCK MOUNT
14	5.372.01	ASSEMBLY ROD PORTAFILTER PRESENCE SWIFT	43	5.V022	1/4-20 UNC X 3-1/4 SOCKET HEAD ALLEN
15	5.372.3.01	COLLAR D9.3 GALVANIZED SWIFT TOWER	44	5.130	MOTOR SHAFT COUPLING
16	5.331	TAMPER IMPELLER	45	5.131	TAMPER SHAFT COLLAR
17	L109.01	BAYONET RING	46	5.V014	S/S #10-32 x 3/8 SOCKET SET SCREW
18	5.353	PORTAFILTER SPACER	47	5.132	TAMPER SHAFT COUPLING
19	5.354	COFFEE CHUTE SPACER	48	5.V015	1/4-20 UNC x 5/8 HEX HEAD SCREW
20	5.371	GASKET. STAINLESS STEEL	49	5.355	THRUST BEARING RETAINER TOP
21	5.V016	#6 X7/8 PAN HEAD PHILLIPS	50	5.106	THRUST BEARING WASHER
22	5.117.1	PIN SWITCH WITHOUT LEVER	51	5.105	THRUST BEARING
23	5.358	THRUST BEARING RETAINER. PLAST	52	5.360	BEARING SPINDLE
24	5.328.01	TAMPER SHAFT (ASSEMBLED WITH 5.109)	53	5.111	SPRING 1,3X25,4X86,5 VARIABLE DIAMETER
25	5.109	ROLL PIN 3/16 x 7/8 420SS	54	5.359	SPRING RETAINER
26	5.V003	#10 EXTERNAL TOOTH LOCK WASHER	55	5.343.2	RUBBER FOR SHAFT LOCK SHOE
27	5.V005	S/S #10-32 UNF HEX NUT	56	5.372.1.01	ROD PORTAFILTER PRESENCE SWIFT TOWER
28	L110.01	SCREW M8X52 SOCKET CAP S/S A2	57	5.372.2	GRUB SCREW UNC 6-32X3 S/S
29	5.V017	#10-32 UNF X 1 Stud tfl (SS)	58	5.357	MOTOR MOUNT
<b>Item</b>	<b>Part number/Codice</b>	<b>Description</b>	<b>Item</b>	<b>Part number/Codice</b>	<b>Description</b>

# GRINDER & ACCESSORIES ASSEMBLY

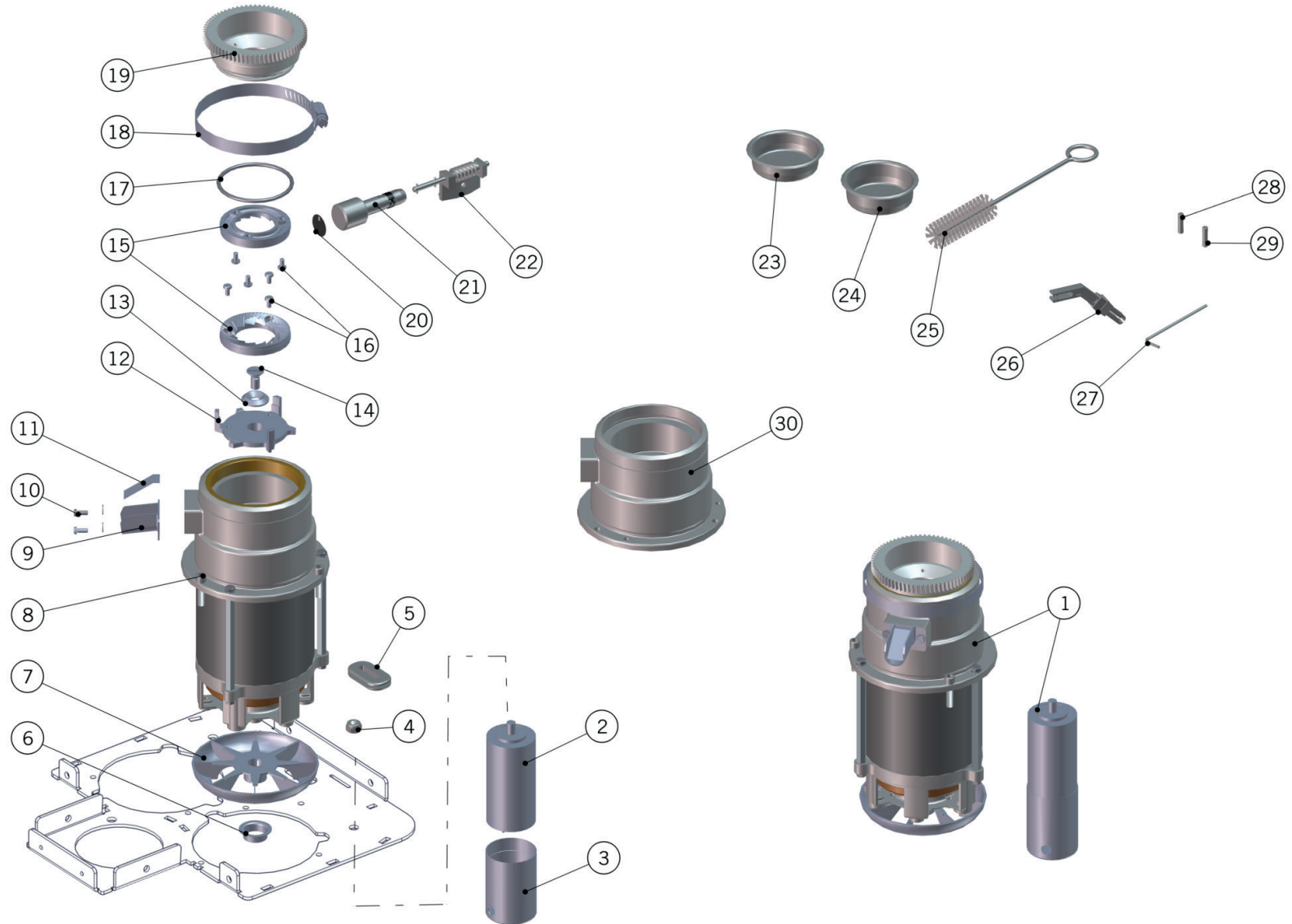



**la marzocco**

handmade in florence

# GRINDER & ACCESSORIES ASSEMBLY

Grinder e Accessori	1	5.200.01	GRINDER MOTOR ASSY 110V	15	5.200.30.01	CERAMIC BURR. (PAIR) STANDARD
		5.201.01	GRINDER MOTOR ASSY 220V	16	5.200.16	SCREW M4X8 A2
	2	5.200.51	CAPACITOR-EMV-64LM 120/60/1 SOLD WITH	17	5.200.55	O-RING BURR MOUNT
		5.200.53	CAPACITOR-EMV-64LM 230/30/1	18	5.200.26	ADJUSTOR CLAMP
	3	5.200.52	CAPACITOR CAP-EMV-64LM	19	5.200.7	STATIONARY GRINDING BURR MOUNT
		5.200.54	CAPACITOR CAP-EMV-64LM	20	5.339.3	KNOB LOCATION INDICATOR DECAL
	4	5.V007	M8 X 1.25 NYLON INSERT LOCK NUT	21	5.338.R	GRIND ADJUSTOR KNOB. 5.338.1 INCLUDED
	5	5.125	GROMMET	22	5.200.31.R	RIGHT GRIND ADJUSTING GEAR W/ROLL PINS
		5.125.1	GROMMET FOR CE POWER CORD		5.200.36.R	LFT GRIND ADJUSTOR GEAR W/ROLL PINS
	6	5.200.27	CLAMP RING FOR FAN	23	5.128	19mm SWIFT FILTER BASKET
	7	5.200.28	FAN BLADE	24	5.127	22mm SWIFT FILTER BASKET
	8	5.V006	1/4-20 UNC X 1" SOCKET HEAD	25	5.118	CLEANING SOFT BRUSH
	9	5.200.10	DISCHARGE	26	5.123	FUSE PULLER
	10	5.200.15	SCREW M4X10 DIN 84	27	5.129	LONG ARM L-KEY. 3/32 HEX SIZE
11	5.200.11	DISCHARGE COVER (LAMINATED SPRING)	28	5.364	FUSE. 1A-SLO	
12	5.200.8	ROTATING GRINDING BURR MOUNT	29	5.363	FUSE. 125MA	
13	5.200.19	CONICAL WASHER	30	5.200.5	HOUSING EMV-64LM	
14	5.200.14	M8X1.25X18MM MACHINE SCREW				
Item	Part number/Codice	Description	Item	Part number/Codice	Description	

LA MARZOCCO SRL  
Via La Torre, 14/H  
Localita' La Torre  
50038 Scarperia e San Piero  
(Florence) - ITALY  
T. +39 055 849 191  
F. +39 055 849 1990  
info@lamarzocco.com  
www.lamarzocco.com